



ENARCO, S.A.

TORNADO

*VIBRATING SCREEDS WITH ELECTRIC OR PETROL ENGINE
HANDYFLOATS TYPE "TORNADO"*



Instruction manual

en





INDEX

1	INTRODUCTION	2
2	CHARACTERISTICS	3
	2.1 CHARACTERISTICS OF THE MOTORS	3
	2.1.1 PETROL ENGINES	3
	2.1.2 ELECTRIC MOTORS	3
	2.2 CHARACTERISTICS OF THE SCREEDS	3
3	USAGE CONDITIONS	5
4	OPERATION AND MAINTENANCE	7
	4.1 GETTING STARTED	7
	4.2 PERIODIC MAINTENANCE	8
	4.3 STORAGE	9
	4.4 TRANSPORTATION	9
5	LOCATING MALFUNCTIONS	9
6	INSTRUCTIONS TO ORDER SPARE PARTS	9
	6.1 INSTRUCTIONS TO ORDER SPARE PARTS	9
	6.2 INSTRUCTIONS TO REQUEST WARRANTIES	9
7	USAGE RECOMMENDATIONS	10
8	ELECTRIC SCHEME	10



1 INTRODUCTION

Thank you for trusting the **ENAR** brand.

For the maximum performance of the equipment, we recommend to read carefully the safety recommendations, maintenance, and usage listed in this manual.

Defective parts should be replaced immediately to avoid major problems.

The effective longevity of the equipment will increase if the manual instructions are followed.

We will be glad to help you with any comments or suggestions in reference to our equipment.



2 CHARACTERISTICS

Light screed for finishing the floors superficially. The main characteristic of this equipment is its low weight; only one person is needed for using it. The use of rail-guide is not necessary, this machine is suitable for working directly on the concrete mass. The aluminium beam has a high resistance and a good flatness. On the screeds with petrol engine, vibration can be controlled with the accelerator lever.

2.1. CHARACTERISTICS OF THE MOTORS:

2.1.1. PETROL ENGINES:

Model ► ▼ characteristics	TORNADO GH - HONDA GX-25	TORNADO GR - ROBIN EH 025
Type/Displacement	4 stroke 25cc	4 stroke 24,5 cc
Max output/R.P.M.	1,1HP 7000 r.p.m.	1,1 HP 7000 r.p.m.
Carburettor	Diaphragm type	Diaphragm type
Ignition	Transistors magneto	Transistors magneto
Starting	Coil	Coil
Fuel	Petrol	Petrol
Fuel tank capacity	550 cc	500 cc
Weight	2,78 kg	2,8 kg

2.1.2 ELECTRIC MOTORS:

Model ► ▼ characteristics	TORNADO E TURBO	TORNADO E TURBO 115V	TORNADO E (electric vibrator)
Power	500W	500W	135W
Max. R.P.M.	12000	12000	2850
Capacitor	-	-	6,3 µF / 220 V
Insulation	Double insulation-IP44	Ground connected-IP44	Ground connected-IP54
Voltage	220v 50-60Hz	115v 50-60Hz	220V 50Hz
Weight	2,6 kg	2,6 kg	4 kg

2.2. CHARACTERISTICS OF THE VIBRATING SCREEDS:

Model ► ▼ characteristics	TORNADO G	TORNADO E	TORNADO E TURBO
Beam length (m)	1,5-4	1,5-4	1,5-4
Weight (kg)	15-23	14,5-22	15-23
Centrifugal force (kp)	150	70	130
Acoustic pressure Lpa (dB)*	113	<70	91,2
Acoustic power Lwa (dB)*	120	-	105,2
Hand-arm vibration (m/s ²)**	13,7	8,6	9,3
Uncertainty K (m/s ²)	6,9	3,5	2,3
Working time for taking anti-vibratory cautions (hours)	0,266	0,676	0,578
Working time limit (hours)	1,06	2,7	2,31

*Noise values measured at the workstation: 1,6m over the floor and 0,2m by the ear of the user.

**Vibration measured in the handle of the vibrating unit (as shown in the picture).

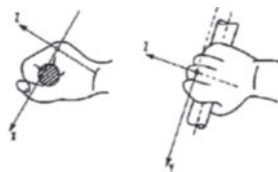

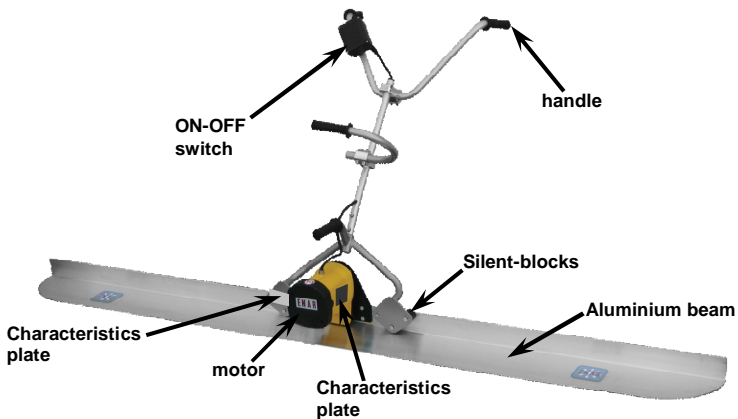
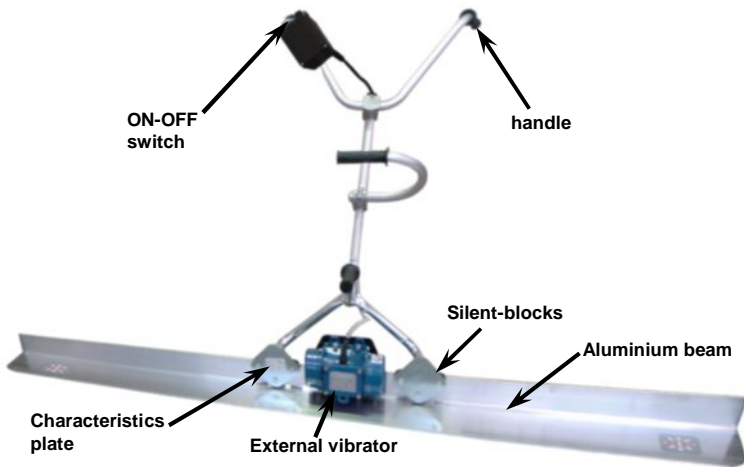
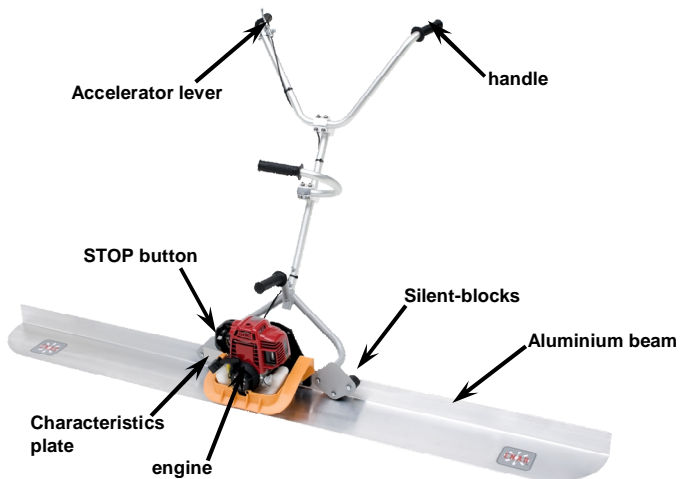

ELECTRIC AND PETROL VIBRATING SCREEDS "TORNADO" TYPE



3 USAGE CONDITIONS



WARNING!



READ AND UNDERSTAND EVERY INSTRUCTION.

WORKING AREA



KEEP your working area clean and well lit. Cluttered benches and dark areas invite accidents.

DO NOT OPERATE power tools in explosive atmospheres, such as in the presence of flammable liquids, gases, or dust.

KEEP AWAY from standers, children, and visitors while operating a power tool. Distractions can cause to loose control.

ELECTRICAL SAFETY



GROUNDING TOOLS MUST BE PLUGGED INTO an outlet properly installed and grounded in accordance with all codes and ordinances.

NEVER REMOVE the grounding prong or modify the plug in any way.

DO NOT USE any plug adaptor.

CHECK with a qualified electrician if you are in doubt as to whether the outlet is properly grounded.

AVOID body contact with grounded surfaces such as pipes, radiators, ranges and refrigerators.

DO NOT EXPOSE power tools to rain or wet conditions.

DO NOT ABUSE the cord.

NEVER USE the cord to carry the tools or the plug from an outlet.

KEEP cord away from heat, oil, sharp edges or moving parts.

REPLACE damaged cords immediately. Damaged cords increase the risk of electric shock.

WHEN OPERATING a power tool outside, use an outdoor extension cord marked "W-A", "W" or "H07RN-F".

PERSONAL SAFETY



STAY ALERT, watch what you are doing and use common sense when operating a power tool.

DO NOT USE THE TOOL while tired or under the influence of drugs, alcohol, or medication.

DRESS properly.

DO NOT WEAR loose clothing or jewellery.

CONTAIN long hair.

KEEP your hair, clothing, and gloves away from moving parts. Loose clothes, jewellery, or long hair can be caught in moving parts.

AVOID accidental starting.

BE SURE switch is off before plugging in. Carrying tools with your finger on the switch or plugging in tools that have the switch on invites accidents.

REMOVE adjusting keys before turning the tool on.

DO NOT overreach.

KEEP properly fed and balanced at all times.

USE safety equipment.

ALWAYS WEAR eye protection. Dust mask, non-skid safety shoes, hard hat, or hearing protection must be used for appropriate conditions.

TOOL USE AND CARE

USE clamps or other practical way to secure and support the work piece to a stable platform.

DO NOT FORCE the tool.

USE the correct tool for your application. The correct tool will do the work better and safer at the rate for which it is designed.

DO NOT USE the tool if the switch does not turn it on neither off.

DISCONNECT the plug from the power source before making any adjustments, changing accessories, or storing the tool.

STORE idle tools out of reach of children and other untrained persons.

MAINTAIN tool with care. KEEP cutting tools sharp and clean.



CHECK for misalignment or binding of moving parts, breakage of parts, and any other condition that may affect the tools operation. If damaged, have the tool serviced before using again.

USE only accessories that are recommended by the manufacturer for your model.

SERVICE



Tool service **MUST BE PERFORMED** only by qualified repair personnel.

When servicing a tool, **USE** only identical replacement parts.

FOLLOW instructions in the Maintenance section of this manual.

SPECIFIC SAFETY RULES

For your own safety, as well as for the others one, and in order not to cause any damage to this equipment, please read carefully the instructions **that are explained as follows**:



1.- For the proper use of this device, please assure that the operator has been correctly informed of the content of this manual before using it.

2.- This screed must be used only under the applications for which it has been designed and according to these safety instructions.



3.- Do not touch any part of the vibrating group when the motor is running.

4.- Do not work in an area exposed to flammable liquids or gases.

5.- Do not allow inexperienced or not trained personnel to use the screed alone.

6.- Always keep the vibrating screed clean and dry.

7.- Please secure all the threads and bolts before working.

8.- Do not stop the screed until the concrete mass is fully vibrated.

9.- Do not work with the screed if any type of malfunction, even small, has been observed.



10.- When working with a petrol screed:

- Read the engine manufacturer's manual before working.

- Do not work in closed rooms, the exhaust fumes may be toxic.

- Wait 2 minutes for the petrol refill until the motor gets cold.



11.- When working with an electric screed:

- Before connecting the motor to the power source, check that the voltage and frequency match the specifications showed in the specifications plate.

- Make sure that the cables have the right section and are in good condition.

- If the screed is connected to a generator, please make sure that the output and voltage specifications are the convenient ones for the model as showed in the specifications plate. The voltage and the frequency must not vary more than 5%.

- Keep the air intake clean and opened for the correct running of the motor.



12.- The acoustic power level of these machines could be a risk for health (see characteristics sheet, point 2.2). Proper protective equipment must be used.



13.- The hand-arm vibration level of these machines could be a risk for health (see characteristics sheet, point 2.2). The screed must always be handled using isolated gloves and all the necessary safety equipment. Besides, the user must rest each hour of effective work.



The rubber parts used for isolating from vibration must be maintained in perfect shape. In case of damage, they must be replaced immediately.

**FURTHERMORE, THE OPERATOR IS COMPELLED
TO RESPECT ADDITIONAL REGULATIONS ENFORCED**



4 OPERATION AND MAINTENANCE

4.1 GETTING STARTED



1.- Before working, make sure that all the security devices are operating under normal conditions.

2.- **WITH PETROL ENGINE:**



Read the engine manufacturer manual.

Do not work in rooms with scarce ventilation.

Make sure there is no flammable good near to the escape.



Check the petrol level in the reservoir (use always unleaded gas in 4 stroke engines).

Check the oil reservoir of the motor is full (see engine manual) in the 4-stroke engine (SAE10W40).

3.- **WITH ELECTRIC MOTOR:**

Before working, switch the motor off with the handle switch.

Check the Current specifications of the power source.

Make sure the cables are in good condition.

Secure the power source is connected to earth on TORNADO E and TORNADO E TURBO 115V screeds.

In the case of using extension cables, read the next section "EXTENSION CABLES".

4.- Check all the bolts are well tighten.

5.- Start the motor, regulate the speed with the accelerator (Petrol) until it reaches a good vibration.

6.- Vibrate the floor by pulling the screed from the handle.

7.- When the work is finished, always remove the fresh concrete that has been settling on the beams and the motor before it sticks to it.



8.- When a defect or a malfunction has been detected, endangering the use of this machine or not, stop the work and make the correspondent maintenance to avoid any danger or bigger damage.

EXTENSION CABLES

In order to protect the operator from an electric shock, please make sure that TORNADO E and TORNADO E TURBO 115V screed models are ground connected.

The TORNADO E and TORNADO E TURBO 115V motors are fitted out with 3 ways cables (2 Phases + ground) and the correspondent plug. The convenient socket must be used.

Do not use damaged cables.

Avoid heavy loads on cables.

To determine the transversal section, read the following procedure:



PROCEDURE TO DETERMINE THE NECESSARY

TRANSVERSAL SECTION IN CABLE EXTENSION

Do the following verifications and take the highest section of cable:

1.- The ohmic resistance and inductive resistance of the cable with the permitted loss of voltage of 2%, $\cos \phi = 0.8$ through the frequency and voltage curve.

I.e.: Nominal voltage: 1- 230 V 50 Hz

Nominal current: 10 A

Cable length: 100 m

Entering the curve with the product: Intensity x Length = $10 \times 100 = 1000$ A m.

We obtain a 4 mm^2 section.

2.- The permitted heating of the cable according to VDE standard (minimum transversal section table required).

I.e.: For 10 A, according to table for 15 A or less, the section is of 1 mm^2 .

Therefore, the section chosen is equal to 4 mm^2 , always chose the highest transversal section of the two verifications.

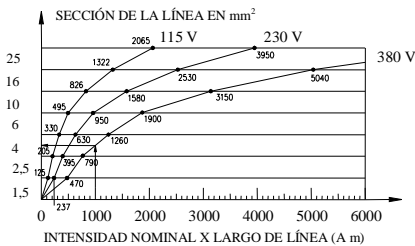

Secciones mínimas según normas VDE		
Sección (mm ²)	Carga máx. (A)	Fusible máx. (A)
1	15	10
1,5	18	10/3-16/1-
2,5	26	20
4	34	25
6	44	35
10	61	50
16	82	63
25	108	80

4.2 PERIODIC MAINTENANCE

MAINTENANCE WITH PETROL ENGINE



- 1.- **Daily (8 hours).**
Clean the engine and the beams, check the bolts & nuts, check and fill the engine reservoir with oil.
- 2.- **Weekly (50 hours).**
Change the motor oil (first 20 hours), clean the sparking plugs and the air filter.
- 3.- **Monthly (200 hours).**
Clean the oil filter, clean and adjust the sparks plugs.
- 4.- **Every 250 hours.** Clean and set the carburettor, clean the cylinder's head, set the valves.
- 5.- Always use original parts by every maintenance operation.
- 6.- The safety fittings have to be checked after every maintenance.
- 7.- **Every 12 months** or more frequently, the screed has to be sent to an authorized workshop for service according to the intensity of the usage.
- 8.- Do not fill the fuel tank while smoking or near any other potential source of danger.
Lock the petrol admission key when filling, use unleaded gas, clean the gas spelt.
- 9.- Idle speed of the motor must not exceed 3.000 rpm. (standard set).
By every maintenance operation, the idle speed of the engine has to be checked and adjusted at 3.000 rpm.
See the engine manual to set the engine speed, starting and stopping.

MAINTENANCE WITH ELECTRIC MOTOR



- 1.- The operating of the electric parts must be done by a specialist.
- 2.- During the maintenance, make sure that the device is disconnected from the power source.
- 3.- Always use original parts by every maintenance operation.
- 4.- The bearings of the motor do not need a periodic maintenance.
- 5.- Inspect the plug, the socket as well as the cables every 100 hours.
- 6.- Clean periodically the housing of the motor to prevent an overheating. **Don't wash the TORNADO E TURBO motor with a high pressure water hose.**
- 7.- **Clean weekly** the TORNADO E TURBO **air inlet filter** (or when 50 hours working) removing the screws of the housing cover 48402.
- 8.- On screeds TORNADO E TURBO check periodically the condition of the brushes and replace them when 120 hours working (brush code 103656).
- 9.- The safety fittings have to be checked after every maintenance.
- 10.- **Every 12 months** or more frequently the screed has to be sent to an authorized workshop for service according to the intensity of the usage.

Re-screw the nuts and bolts daily.



4.3 STORAGE

Always store the screed in a clean and dry area when not used for a long period of time.

4.4 TRANSPORTATION

Make sure the screed won't suffer any ripping or shock that could cause any damage.

5 LOCATING MALFUNCTIONS

PROBLEM	CAUSES/SOLUTIONS
The motor doesn't work	Check the gas level.
	Check the gas admission key is open.
	Check the de choke position (gas).
	Check the power source (electric).
	Check the brushes condition (electric Turbo)
The screed doesn't vibrate	Check the cables, the switch and the plug (electric).
	Check the engine oil level.
The electric motor is overheating	Check the exciter's transmission.
	Clean the air ventilation (inlet and outlet).
	Check the power supply type.

6 INSTRUCTIONS TO ORDER SPARE PARTS

6.1 INSTRUCTIONS TO ORDER SPARE PARTS



1.- Every spare parts order must include PART CODE NUMBER AS STATED IN THE PARTS LIST. We recommend including the MACHINE SERIAL NUMBER.

2.- The identification plate with serial and model number is located as shown in the point 2 of this manual.

3.- Let us to know the right shipping instructions, including the wished route, the address and the consignee complete name.

4.- Do not return the parts without authorisation, the return is done with freight prepaid.

6.2 INSTRUCTIONS TO REQUEST WARRANTIES



1.- The warranty is valid for 1 year after the purchasing of the machine, the warranty will cover parts with manufacturing defects. In any case the warranty will cover a malfunction due to improper usage of the equipment.

2.- In all warranty requests THE MACHINE MUST BE SENT TO ENARCO, S.A. or to an AUTHORIZED DEALER, always including the complete address and name of the consignee.

3.- The Technical Assistance Service will immediately notify to the customer if the warranty is accepted and, if requested, it will send a technical report.

4.- The warranty will be void if any equipment has been previously handled by personnel outside of ENARCO, S.A. or not authorized by it.

NB: ENARCO, S.A., reserves the right to modify any part of this manual without prior notice.



7 USAGE RECOMMENDATIONS

The screeds are used to the vibration and the finishing of the floors. This work can be made directly on the surface without guides. Thanks to its lightweight and to its mechanism producing a powerful vibration, the screed is ideal to smooth rapidly and easily the floors (from 6 to 18 cm thickness) depending on the concrete type.

In order to get a good finishing of the concrete surface, we recommend following these instructions:

- 1.- Before pouring the concrete mass on the structure, it is necessary to level properly the concrete mass. To get a right compaction of the concrete, you should use the vibrating pokers additionally. It's important to take references or levels out of the mass to see the level objective clearly. The marks of the feet and the tool disappear after the last pass of the screed. The vibration wave produced, reaches a depth of 18 cm depending on the type of concrete mass.
- 2.- When the mass is prepared, the screed is laid over the concrete mass with the motor running at the top speed and you must support the handle lightly in order to avoid the screed jumps over the surface and does not create "waves" and "marks" with edges. Pull and push constantly the screed. It is important to get a smooth surface. The screed must be in contact with the concrete. The screed must not show any resistance to pulling, it must slip over the concrete. The speed to push and pull the screed depends on the depth and the consistency of the mass.
- 3.- To judge the quality of the vibration, the marks of the feet and the beam must disappear. In case of the concrete is not really smooth, repeat the previous instruction.
- 4.- Then, a mixture called "milk" appears on the surface (this is a mixture of 3-4 mm thickness composed of water, concrete, and small sand particles).
- 5.- Water must evaporate quickly and the surface will become dull. The fine layer called "milk" is acting as a cinder paper for the below layers and avoids the sweating effect. The water stays in the below layers and the surface moistens.
- 6.- Several hours later, the concrete is ready for additional finishing operations. You can use a trowel (single or double ride-on-type) or re-vibration equipment (double roller unit with integrated vibrating system). These machines provide a higher resistance to wearing but are not required for all the types of floors.

8 ELECTRIC SCHEME

TORNADO E

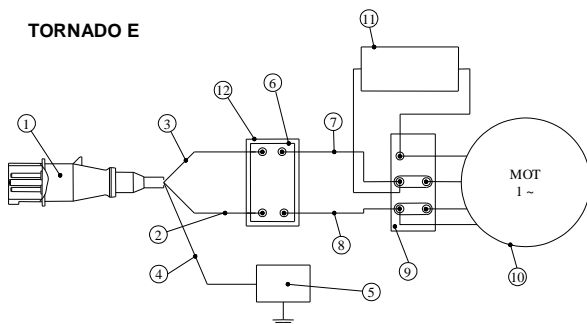

TORNADO E TURBO

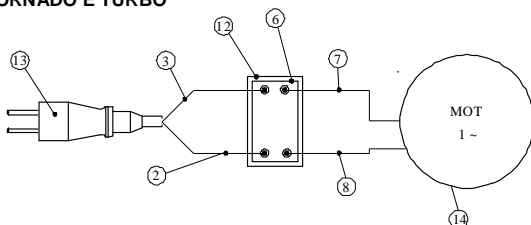

1	2P+T or Schuko plug
2	Cable to switch section 1,5mm ²
3	Cable to switch section 1,5mm ²
4	Earth cable (green-yellow)
5	Earth connection point
6	Switch
7	Cable to motor section 1,5mm ²
8	Cable to motor section 1,5mm ²
9	Terminals box
10	Motor
11	capacitor
12	Switch box
13	2P Schuko plug
14	Monophase motor set



PARA REALIZAR CUALQUIER CONSULTA SOBRE LOS DESPIECES Y LISTAS DE PIEZAS DE NUESTRAS MQUINAS CONSULTE NUESTRA PGINA WEB.

FOR ANY REQUIREMENT ABOUT THE PART LIST OF OUR MACHINES CONSULT OUR WEB PAGE.

POUR CONSULTER TOUS LES RENSEIGNEMENTS DES PICES DETACHEES OU LA LISTE DE NOS MACHINES VOIR NOTRE SITE.

UM DIE VERSCHIEDENE EXPLOSIONSZEICHNUNGEN SO WIE DIE ERSATZTEILLISTEN EINZUSEHEN, BESUCHEN SIE BITTE UNSERE INTERNET-SEITE.



www.enar.es

**DECLARACIÓN DE CONFORMIDAD**

CONFORMITY CERTIFICATE ~ CERTIFICAT DE CONFORMITÉ
 INSTEMMING VERKLARING ~ KONFORMITÄTS BESCHEINIGUNG
 KONFORMITETS BEVIS ~ CERTIFICATO DE CONFORMIDADE ~ CERTIFICATO DI CONFORMITA'
 ATITIKTIKTES DEKLARACIJA ~ CERTYFIKAT ZGODNOŚCI ~ СЕРТИФИКАТ СООТВЕТСТВИЯ
 CERTIFICAT DE CONFORMITATE ~ СЕРТИФИКАТ ЗА СЪОТВЕТСТВИЕ

ENARCO, S.A.**certifica que la máquina especificada**

hereby certify that the equipment specified below ~ atteste que le equipment
 verklaart hierbij dat onderstaand gespecificeerde ~ bescheinigt, daß das Baugerät
 bekræfter, at følgende maskine ~ certifica que o equipamento especificação

certifica che la macchina specificata ~ šiuo sertifikatu patvirtina, kad žemiau nurodytas prietaisas, t.y.
 Zaświadcza, że wyszczególniona maszyna ~ Подтверждает, что нижеописанная машина
 Certifica si declara ca echipamentul mentionat mai jos ~ Потвърждаваме, че оборудването, описано по-долу

TIPO DE MAQUINA	Grupo REGLA TORNADO
TYPE-TYPE-TYPE-TYP-TYPE-TIPO-TIPO-TIPAS-TYP-ТИП-ТИП-ТИП	TORNADO SCREED unit
	Groupe REGLE TORNADO
	PATSCHHEINHEIT TORNADO
MODELO	TORNADO GH / TORNADO GR /
MODEL-MODÈLE-MODEL-MODEL-MODEL-MODELO	TORNADO E / TORNADO E TURBO
MODELLO MODELIS-MODEL-МОДЕЛЬ-MODEL-МОДЕЛ	TORNADO E TURBO 115V
CODIGO	3483XX, 3484XX
CODE-CODE-CODE-CODE-CODIGO-CODICE-KODAS-KOD	
КОД- КОД - КОД	

ha sido fabricada de acuerdo con las siguientes normas

has been manufactured according to the following standards ~ est produit conforme aux dispositions des directives ci-apres
 in overeenstemming met de volgende voorschriften gefabriceerd is ~ in übereinstimmung mit folgenden richtlinien hergestellt worden ist
 er blevet fremstillet i overensstemmelse med følgende retningslinier ~ é fabricado conforme as seguintes normas
 è stata fabbricata secondo le norme vigenti ~ buvo pagamintas laikantis toliau išvardintų standartų
 została wyprodukowana zgodnie z następującymi normami ~ Произведена в соответствии со следующими нормами
 este fabricat cu respectarea urmatoarelor standarde ~ е произведено в съответствие със следните стандарти

2006/42/CE, 2000/14/CE, EN-12649
2014/35/CE*, 2014/30/CE*, 2002/95/EC*, 2002/96/EC*
 *Applicable for machines with electric motor

RESPONSABLE DOCUMENTACIÓN TÉCNICA..... Jesus Tabuenca (ENARCO, S.A. Burtina, 16, 50197 Zaragoza)
 Technical documentation responsible ~ Responsable of the Documentation Technique ~ zuständigen technischen Dokumentation

Zaragoza, 10.06.2014

David Gascón
 General Manager
ENARCO, S.A.

ENARCO, S.A.

C/ Burtina 16
 Plataforma logística PLAZA
 50197 ZARAGOZA

Tfno. (34) 976 464 090
 (34) 976 464 091
 Fax (34) 976 471 470

e-mail: enar@enar.es
 Web: http://www.enar.es