

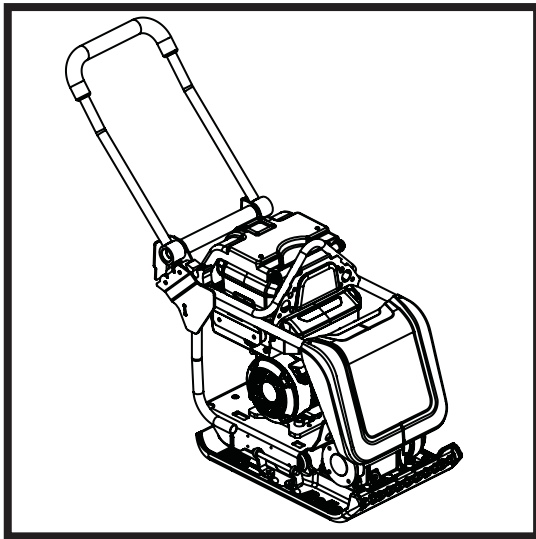

BELLE PCX 13/40E+

870/10026/1
11/22



Ⓒ Operators Manual

8

2

UKCA Declaration of Conformity

3 - 7

EC/EU Declaration of Conformity

Declaration Of Conformity (DOC)

We, **Altrad Belle, Sheen, Nr. Buxton, Derbyshire, SK17 0EU, GB** declare that the DoC is issued under our sole responsibility and belongs to the followings product(s):



PRODUCT TYPE

MODEL.....

SERIAL No.....

DATE OF MANUFACTURE

SOUND POWER LEVEL
MEASURED /
.....(GUARANTEED)

WEIGHT.....



Object of the Declaration:

Battery powered single-direction plate compactor used for soil compaction on new developments, repairs and maintenance jobs with large aggregates, cohesive material or moist content.

The object of the declaration described above is in conformity with the relevant **Statutory Requirements:**

- **2008 No. 1597** Supply of Machinery (Safety) Regulations 2008
- **2001 No. 1701** Noise Emission in the Environment by Equipment for use Outdoors Regulations 2001
- **2016 No. 1091** Electromagnetic Compatibility Regulations 2016
- **2012 No. 3032** The Restriction of the Use of Certain Hazardous Substances in Electrical and Electronic Equipment Regulations 2012

The following designated standards and technical specifications have been applied:

- **EN ISO 12100:2010** Safety of machinery
- **EN 500-4:2011** Mobile road construction machinery. Safety.
- **ISO 3744:2010** Acoustics — Determination of sound power levels and sound energy levels of noise sources using sound pressure

ANP CERTIFICATION LTD. (Approved Body, number 8500) 2 Parkfield Street, Manchester, M14 4PN, UK carried out Internal Control of Production with Assessment of Technical Documentation and Periodical Checking as per Schedule 9 of SI 2001 1701

Technical Files are held by **Ray Neilson** at the Altrad Belle address stated above:-

Place of Declaration:-

Sheen,
Nr. Buxton,
Derbyshire,
SK17 0EU,
UK

Signed by:

Ray Neilson

Date of Declaration:-

February 2022

Managing Director
On behalf of Altrad Belle
Sheen, Derbyshire, UK



EC Declaration Of Conformity (DOC)



We, **Altrad Belle, Sheen, Nr. Buxton, Derbyshire, SK17 0EU, GB** declare that the DoC is issued under our sole responsibility and belongs to the followings product(s):



PRODUCT TYPE
MODEL.....
SERIAL No.....
DATE OF MANUFACTURE
SOUND POWER LEVEL MEASURED /(GUARANTEED)
WEIGHT.....



Signed by:

Ray Neilson
Managing Director

On behalf of Altrad Belle, Sheen, Derbyshire, UK

Place of Declaration:-
Sheen, Nr. Buxton, Derbyshire, SK17 0EU, UK
Date of Declaration:-
February 2022

Object of the Declaration:

Battery powered single-direction plate compactor used for soil compaction on new developments, repairs and maintenance jobs with large aggregates, cohesive material or moist content.

The object of the declaration described above is in conformity with the relevant **Union Harmonisation Legislation:**
- **2006/42/EC** - New machinery directive - **2000/14/EC** - Noise - equipment for use outdoors

The following harmonised standards and technical specifications have been applied:

- **EN ISO 12100:2010** Safety of machinery
- **EN 500-4:2011** Mobile road construction machinery. Safety.
- **ISO 3744:2010** Acoustics — Determination of sound power levels and sound energy levels of noise sources using sound pressure

VINÇOTTE nv/sa (NB0026) carried out Internal Control of Production with Assessment of Technical Documentation and Periodical Checking as per Annex VI of 2000/14/EC

Technical Files are held by **Hugues Menager** at the following address:-
Altrad (Group Holding), 125 Rue du Mas Carbonnier, 34000, Montpellier, France.



EU Declaration Of Conformity (DOC)



We, **Altrad Belle, Sheen, Nr. Buxton, Derbyshire, SK17 0EU, GB** declare that the DoC is issued under our sole responsibility and belongs to the followings product(s):



PRODUCT TYPE
MODEL.....
SERIAL No.....
DATE OF MANUFACTURE
SOUND POWER LEVEL MEASURED /(GUARANTEED)
WEIGHT.....

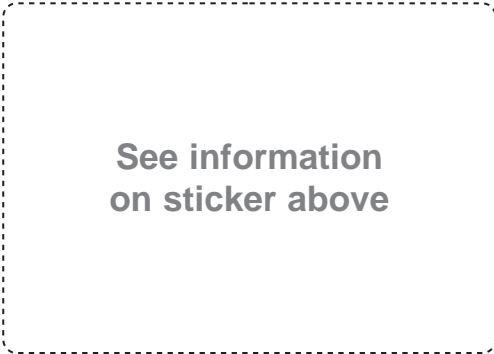

Signed by:

Ray Neilson
Managing Director

On behalf of Altrad Belle, Sheen, Derbyshire, UK

Place of Declaration:-
Sheen, Nr. Buxton, Derbyshire, SK17 0EU, UK
Date of Declaration:-
February 2022

Object of the Declaration:

Battery powered single-direction plate compactor used for soil compaction on new developments, repairs and maintenance jobs with large aggregates, cohesive material or moist content.

The object of the declaration described above is in conformity with the relevant **Union Harmonisation Legislation:**
- **2014/30/EU** - EMC Directive - **2011/65/EU** - Restriction of Hazardous Substances Directive

The following harmonised standards and technical specifications have been applied:

- **EN ISO 12100:2010** Safety of machinery
- **EN 500-4:2011** Mobile road construction machinery. Safety.
- **ISO 3744:2010** Acoustics — Determination of sound power levels and sound energy levels of noise sources using sound pressure

VINÇOTTE nv/sa (NB0026) carried out Internal Control of Production with Assessment of Technical Documentation and Periodical Checking as per Annex VI of 2000/14/EC

Technical Files are held by **Hugues Menager** at the following address:-
Altrad (Group Holding), 125 Rue du Mas Carbonnier, 34000, Montpellier, France.

F

Déclaration CE de conformité (DdC)

F

Nous, **Altrad Belle, Sheen, Nr. Buxton, Derbyshire, SK17 0EU, GB** déclarons que la DdC est émise sous notre seule responsabilité et qu'elle appartient au(x) produit(s) suivants:



TYPE DE PRODUIT.....

MODÈLE

No DE SÉRIE

DATE DE FABRICATION.....

NIVEAU DE PUISSANCE
ACOUSTIQUE MESURÉ /
.....(GARANTI)

POIDS

Voir page 3
pour cette information

Signée par:

Ray Neilson

Directeur Général

Au nom de Altrad Belle, Sheen, Derbyshire, R.-U.

Lieu de la déclaration:-
Sheen, Nr. Buxton, Derbyshire, SK17 0EU, UK

Date de la déclaration:-
Fevrier 2022

Objet de la déclaration:

Compacteur à plaque unidirectionnelle alimenté par batterie utilisé pour le compactage du sol sur les nouveaux développements, les réparations et les travaux d'entretien avec de gros agrégats, un matériau cohésif ou une teneur en humidité..

L'objet de la déclaration décrite ci-dessus est conforme à la **législation de l'Union européenne en matière d'harmonisation:**

- **2006/42/EC** - Directive relative aux machines

- **2000/14/EC** - Émissions sonores - matériels utilisés à l'extérieur

Les normes et les spécifications techniques harmonisées suivantes ont été appliquées:

- **EN ISO 12100:2010** Sécurité des machines
- **EN 500-4:2011** Machines mobiles de construction de routes. Sécurité.
- **ISO 3744:2010** Acoustique - Détermination des niveaux de puissance acoustique et des niveaux d'énergie acoustique des sources de bruit à l'aide de la pression acoustique

VINÇOTTE nv/sa (NB0026) a effectué un contrôle interne de la production avec évaluation de la documentation technique et vérification périodique conformément à l'annexe VI de la directive 2000/14/CE

Les dossiers techniques sont détenus par **Hugues Menager** à l'adresse suivante:-
Altrad (Group Holding), 125 Rue du Mas Carbonnier, 34000, Montpellier, France.

F

Déclaration UE de conformité (DdC)

F

Nous, **Altrad Belle, Sheen, Nr. Buxton, Derbyshire, SK17 0EU, GB** déclarons que la DdC est émise sous notre seule responsabilité et qu'elle appartient au(x) produit(s) suivants:



TYPE DE PRODUIT.....

MODÈLE

No DE SÉRIE

DATE DE FABRICATION.....

NIVEAU DE PUISSANCE
ACOUSTIQUE MESURÉ /
.....(GARANTI)

POIDS

Voir page 3
pour cette information

Signée par:

Ray Neilson

Directeur Général

Au nom de Altrad Belle, Sheen, Derbyshire, R.-U.

Lieu de la déclaration:-
Sheen, Nr. Buxton, Derbyshire, SK17 0EU, UK

Date de la déclaration:-
Fevrier 2022

Objet de la déclaration:

Compacteur à plaque unidirectionnelle alimenté par batterie utilisé pour le compactage du sol sur les nouveaux développements, les réparations et les travaux d'entretien avec de gros agrégats, un matériau cohésif ou une teneur en humidité..

L'objet de la déclaration décrite ci-dessus est conforme à la **législation de l'Union européenne en matière d'harmonisation:**

- **2014/30/EU** - Directive CEM

Les normes et les spécifications techniques harmonisées suivantes ont été appliquées:

- **EN ISO 12100:2010** Sécurité des machines
- **EN 500-4:2011** Machines mobiles de construction de routes. Sécurité.
- **ISO 3744:2010** Acoustique - Détermination des niveaux de puissance acoustique et des niveaux d'énergie acoustique des sources de bruit à l'aide de la pression acoustique

VINÇOTTE nv/sa (NB0026) a effectué un contrôle interne de la production avec évaluation de la documentation technique et vérification périodique conformément à l'annexe VI de la directive 2000/14/CE

Les dossiers techniques sont détenus par **Hugues Menager** à l'adresse suivante:-
Altrad (Group Holding), 125 Rue du Mas Carbonnier, 34000, Montpellier, France.

E

Declaración CE de Conformidad (DDC)

E

Nosotros, **Altrad Belle, Nr. Buxton, Derbyshire, SK17 0EU, Gran Bretaña**, declaramos que la DDC se emite bajo nuestra responsabilidad exclusiva y concierne a los siguientes productos:



TIPO DE PRODUCTO.....

MODELO.....

NÚMERO DE SERIE.....

FECHA DE FABRICACIÓN

NIVEL DE POTENCIA
ACÚSTICA MEDIDO /.....
.....GARANTIZADO)

PESO

Ver página 3
para esta información

Firmado por:

Ray Neilson
Director General

Por Altrad Belle Sheen, Derbyshire, Reino Unido

Lugar de la Declaración:-
Sheen, Nr. Buxton, Derbyshire, SK17 0EU, UK

Fecha de la Declaración:-
Febrero 2022

Objeto de la declaración:

Compactador de placa monodireccional a batería utilizado para la compactación de suelos en nuevos desarrollos, trabajos de reparación y mantenimiento con grandes áridos, material cohesivo o contenido húmedo..

El objeto de la declaración antes descrita está conforme a la **Legislación sobre armonización de la Unión** relevantes:

- **2006/42/EC** - Nueva directiva relativa a las máquinas

- **2000/14/EC** - Emisiones sonoras - máquinas de uso al aire libre

Las siguientes normas armonizadas y especificaciones técnicas han sido aplicadas:

- **EN ISO 12100:2010** Seguridad de la maquinaria

- **EN 500-4:2011** Maquinaria de construcción de carreteras móviles. Seguridad.

- **ISO 3744:2010** Acústica: determinación de los niveles de potencia acústica y energía acústica niveles de fuentes de ruido usando presión sonora

VINÇOTTE nv/sa (NB0026) realizó un control interno de producción con evaluación de documentación técnica y verificación periódica de conformidad con el anexo VI de 2000/14/CE

Los archivos técnicos están en poder de **Hugues Menager** en la siguiente dirección:-
Altrad (Group Holding), 125 Rue du Mas Carbonnier, 34000, Montpellier, Francia.

E

Declaración UE de Conformidad (DDC)

E

Nosotros, **Altrad Belle, Nr. Buxton, Derbyshire, SK17 0EU, Gran Bretaña**, declaramos que la DDC se emite bajo nuestra responsabilidad exclusiva y concierne a los siguientes productos:



TIPO DE PRODUCTO.....

MODELO.....

NÚMERO DE SERIE.....

FECHA DE FABRICACIÓN

NIVEL DE POTENCIA
ACÚSTICA MEDIDO /.....
.....GARANTIZADO)

PESO

Ver página 3
para esta información

Firmado por:

Ray Neilson
Director General

Por Altrad Belle Sheen, Derbyshire, Reino Unido

Lugar de la Declaración:-
Sheen, Nr. Buxton, Derbyshire, SK17 0EU, UK

Fecha de la Declaración:-
Febrero 2022

Objeto de la declaración:

Compactador de placa monodireccional a batería utilizado para la compactación de suelos en nuevos desarrollos, trabajos de reparación y mantenimiento con grandes áridos, material cohesivo o contenido húmedo..

El objeto de la declaración antes descrita está conforme a la **Legislación sobre armonización de la Unión** relevantes:

- **2014/30/EU** Directiva CEM

Las siguientes normas armonizadas y especificaciones técnicas han sido aplicadas:

- **EN ISO 12100:2010** Seguridad de la maquinaria

- **EN 500-4:2011** Maquinaria de construcción de carreteras móviles. Seguridad.

- **ISO 3744:2010** Acústica: determinación de los niveles de potencia acústica y energía acústica niveles de fuentes de ruido usando presión sonora

VINÇOTTE nv/sa (NB0026) realizó un control interno de producción con evaluación de documentación técnica y verificación periódica de conformidad con el anexo VI de 2000/14/CE

Los archivos técnicos están en poder de **Hugues Menager** en la siguiente dirección:-
Altrad (Group Holding), 125 Rue du Mas Carbonnier, 34000, Montpellier, Francia.

D

EG-Konformitätserklärung (DOC)

D

Wir, **Altrad Belle, Sheen, Nr. Buxton, Derbyshire, SK17 0EU, GB** erklären, dass vorliegende Konformitätserklärung unter unserer alleinigen Verantwortung ausgestellt wurde und sich auf folgende(s) Produkt(e) bezieht:



PRODUKTTYP.....
 MODELL
 SERIENNUMMER.....
 HERSTELLUNGSDATUM
 SCHALLLEISTUNGSPEGEL
 GEMESSEN /
 (GARANTIERT)
 GEWICHT.....

Siehe Seite 3
für diese Informationen

Unterzeichnet von:

Ray Neilson

Geschäftsführender Direktor

Im Namen von Altrad Belle, Sheen, Derbyshire, UK

Ort der Erklärung:-

Sheen, Nr. Buxton, Derbyshire, SK17 0EU, UK

Datum der Erklärung:-

Februar 2022

Gegenstand der Erklärung:

Batteriebetriebener Einweg-Plattenverdichter zur Bodenverdichtung bei Neuentwicklungen, Reparaturen und Wartungsarbeiten mit großen Zuschlagstoffen, bindigem Material oder feuchtem Inhalt.

Gegenstand der oben beschriebenen Erklärung ist die Konformität mit den einschlägigen Harmonisierungsrechtsvorschriften der Union:
 - **2006/42/EG** - Neue Maschinenrichtlinie - **2000/14/EG** - Lärm - Geräte und Maschinen zur Verwendung im Freien

Die folgenden harmonisierten Normen und technischen Spezifikationen wurden angewandt:

- **EN ISO 12100:2010** Sicherheit von Maschinen
- **EN 500-4:2011** Mobile Straßenbaumaschinen. Sicherheit.
- **ISO 3744:2010** Akustik - Bestimmung von Schallleistungspegeln und Schallenergie Pegel der Geräuschquellen unter Verwendung des Schalldrucks

VINÇOTTE nv/sa (NB0026) hat die interne Fertigungskontrolle mit Bewertung der technischen Dokumentation und periodischer Prüfung gemäß Anhang VI der Richtlinie 2000/14/EG durchgeführt.

Die technischen Unterlagen werden von **Hugues Menager** unter folgender Adresse aufbewahrt: -
Altrad (Group Holding), 125 Rue du Mas Carbonnier, 34000, Montpellier, Frankreich.

D

EU-Konformitätserklärung (DOC)

D

Wir, **Altrad Belle, Sheen, Nr. Buxton, Derbyshire, SK17 0EU, GB** erklären, dass vorliegende Konformitätserklärung unter unserer alleinigen Verantwortung ausgestellt wurde und sich auf folgende(s) Produkt(e) bezieht:



PRODUKTTYP.....
 MODELL
 SERIENNUMMER.....
 HERSTELLUNGSDATUM
 SCHALLLEISTUNGSPEGEL
 GEMESSEN /
 (GARANTIERT)
 GEWICHT.....

Siehe Seite 3
für diese Informationen

Unterzeichnet von:

Ray Neilson

Geschäftsführender Direktor

Im Namen von Altrad Belle, Sheen, Derbyshire, UK

Ort der Erklärung:-

Sheen, Nr. Buxton, Derbyshire, SK17 0EU, UK

Datum der Erklärung:-

Februar 2022

Gegenstand der Erklärung:

Batteriebetriebener Einweg-Plattenverdichter zur Bodenverdichtung bei Neuentwicklungen, Reparaturen und Wartungsarbeiten mit großen Zuschlagstoffen, bindigem Material oder feuchtem Inhalt.

Gegenstand der oben beschriebenen Erklärung ist die Konformität mit den einschlägigen Harmonisierungsrechtsvorschriften der Union:
 - **2014/30/EU** - EMV-Richtlinie

Die folgenden harmonisierten Normen und technischen Spezifikationen wurden angewandt:

- **EN ISO 12100:2010** Sicherheit von Maschinen
- **EN 500-4:2011** Mobile Straßenbaumaschinen. Sicherheit.
- **ISO 3744:2010** Akustik - Bestimmung von Schallleistungspegeln und Schallenergie Pegel der Geräuschquellen unter Verwendung des Schalldrucks

VINÇOTTE nv/sa (NB0026) hat die interne Fertigungskontrolle mit Bewertung der technischen Dokumentation und periodischer Prüfung gemäß Anhang VI der Richtlinie 2000/14/EG durchgeführt.

Die technischen Unterlagen werden von **Hugues Menager** unter folgender Adresse aufbewahrt: -
Altrad (Group Holding), 125 Rue du Mas Carbonnier, 34000, Montpellier, Frankreich.

PL

Deklaracja zgodności WE (DOC)

PL

My, **Altrad Belle, Sheen, Nr. Buxton, Derbyshire, SK17 0EU, Wielka Brytania**, oświadczamy, że deklaracja zgodności została wydana na naszą wyłączną odpowiedzialność i należy do następującej grupy produktów:



RODZAJ PRODUKTU

MODEL.....

Nr SERII

DATA PRODUKCJI.....

POZIOM MOCY DŹWIĘKU
MIERZONY /

MASA

**Patrz strona 3
za te informacje**

Podpisał:

Ray Neilson

Dyrektor Zarządzający

W imieniu Altrad Belle Sheen, Derbyshire, UK

Miejsce deklaracji:

Sheen, Nr. Buxton, Derbyshire, SK17 0EU, UK

Data deklaracji:

Luty 2022

Przedmiot, którego deklaracja dotyczy::

Jednokierunkowa zagęszczarka płytowa zasilana bateryjnie, używana do zagęszczania gruntu na nowych osiedlach, naprawach i pracach konserwacyjnych z dużymi kruszywami, spoistym materiałem lub zawartością wilgoci.

Opisany powyżej przedmiot objęty deklaracją jest zgodny z unijnym prawodawstwem harmonizacyjnym::

- **2006/42/WE** - Nową dyrektywą maszynową - **2000/14/WE** - Emisja hałasu do środowiska przez urządzenia używane na zewnątrz pomieszczeń

Zastosowano następujące scharmonizowane normy i specyfikacje techniczne:

- **EN ISO 12100:2010** Bezpieczeństwo maszyn
- **EN 500-4:2011** Mobilne maszyny drogowe. Bezpieczeństwo.
- **ISO 3744:2010** Akustyka - Wyznaczanie poziomów mocy akustycznej i energii akustycznej poziomych źródeł hałasu wykorzystujących ciśnienie akustyczne

VINÇOTTE nv / sa (NB0026) przeprowadził wewnętrzną kontrolę produkcji wraz z analizą dokumentacji technicznej i okresowymi kontrolami zgodnie z załącznikiem VI 2000/14 / WE

Pliki techniczne są przechowywane przez **Hugues Menager** pod następującym adresem: - **Altrad (Group Holding)**, 125 Rue du Mas Carbonnier, 34000, Montpellier, Francja.

PL

Deklaracja zgodności UE (DOC)

PL

My, **Altrad Belle, Sheen, Nr. Buxton, Derbyshire, SK17 0EU, Wielka Brytania**, oświadczamy, że deklaracja zgodności została wydana na naszą wyłączną odpowiedzialność i należy do następującej grupy produktów:



RODZAJ PRODUKTU

MODEL.....

Nr SERII

DATA PRODUKCJI.....

POZIOM MOCY DŹWIĘKU
MIERZONY /

MASA

**Patrz strona 3
za te informacje**

Podpisał:

Ray Neilson

Dyrektor Zarządzający

W imieniu Altrad Belle Sheen, Derbyshire, UK

Miejsce deklaracji:

Sheen, Nr. Buxton, Derbyshire, SK17 0EU, UK

Data deklaracji:

Luty 2022

Przedmiot, którego deklaracja dotyczy::

Jednokierunkowa zagęszczarka płytowa zasilana bateryjnie, używana do zagęszczania gruntu na nowych osiedlach, naprawach i pracach konserwacyjnych z dużymi kruszywami, spoistym materiałem lub zawartością wilgoci.

Opisany powyżej przedmiot objęty deklaracją jest zgodny z unijnym prawodawstwem harmonizacyjnym::

- **2014/30/UE** - Dyrektywą kompatybilności elektromagnetycznej EMC

Zastosowano następujące scharmonizowane normy i specyfikacje techniczne:

- **EN ISO 12100:2010** Bezpieczeństwo maszyn
- **EN 500-4:2011** Mobilne maszyny drogowe. Bezpieczeństwo.
- **ISO 3744:2010** Akustyka - Wyznaczanie poziomów mocy akustycznej i energii akustycznej poziomych źródeł hałasu wykorzystujących ciśnienie akustyczne

VINÇOTTE nv / sa (NB0026) przeprowadził wewnętrzną kontrolę produkcji wraz z analizą dokumentacji technicznej i okresowymi kontrolami zgodnie z załącznikiem VI 2000/14 / WE

Pliki techniczne są przechowywane przez **Hugues Menager** pod następującym adresem: - **Altrad (Group Holding)**, 125 Rue du Mas Carbonnier, 34000, Montpellier, Francja.

866/10005/0_PL



<u>CONTENTS</u>	<u>PAGE NUMBER</u>
UKCA DECLARATION OF CONFORMITY	2
CE/EU DECLARATION OF CONFORMITY	3
INTRODUCTION	9
WARNING	9
Serial Numbers.....	10
MACHINE DESCRIPTION	
General.....	11
Standard Operation	11
Danger Zone	11
Main Components Locations.....	12
Power Unit Components	13
Battery Pack Components.....	13
Battery Charger	14
TECHNICAL DATA	
Static Dimensions.....	15
General Data	16
Battery Pack Data	16
SAFETY INSTRUCTIONS	
General.....	17
Pre-Start Checks	17
Worksites.....	17
Operating the Machine	17
Battery Charger	18
Battery Pack	19
Weather Conditions.....	19
During Maintenance	19
After Maintenance	19
Modifications & Replacement Parts	19
Safety Decals	20 - 21
OPERATING INSTRUCTIONS	
Reasons for Compaction.....	22
Applications.....	22
Charging the Battery Pack	23
Attaching the Battery Pack	23
Stopping the Power Unit.....	23
Starting the Power Unit	23
Removing the Battery Pack.....	23
Check the Charge Level of the Battery Pack	24
Transportation	24
Operating the Machine	24
STORAGE	25
SERVICE AND MAINTENANCE	
General.....	26
Maintenance Schedule.....	26
Drive Belt.....	27
Vibrator Unit	27
Cleaning	27
TROUBLESHOOTING GUIDE	
Power Unit & Operation.....	28
Battery Back	29
Battery Charger	29
ENVIRONMENT	30
REPLACEMENT PARTS	30
WARRANTY	31

The purpose of this publication is to enable the owner/operator to maintain and use the machine efficiently. If these instructions are followed carefully they will contribute to years of efficient and profitable operation of the machines in the true Altrad Belle tradition.

The variations in operating conditions make it impossible for the company to make comprehensive or definite statements in its publications regarding performance and methods of use of its machines, or to accept any liability for any loss or damage which may result from these statements, or from any errors or omissions.

When replacements are required, insist on genuine Altrad Belle parts, as extensive damage is liable to result from the use of inferior quality parts.

In accordance with the company's policy of continuous improvement to its machines, alteration to the specifications of machines may be made at any time without notice and the company accepts no responsibility for any discrepancies which may occur between the specifications of its machines and the descriptions thereof contained in this publications.

This manual has been written to include all factory fitted options and specifications for world-wide use, but this does not imply that all or any of these are included in the standard machine configuration. Therefore local Altrad Belle Dealer's must always be consulted about machine specifications.

This manual may not in part, or in whole, be copied, photocopied, reproduced, translated, or converted to any electronic or machine readable form without written consent of Altrad Belle.

Directives with regard to the notations.

Text in this manual to which special attention must be paid are shown in the following way:



CAUTION

The product can be at risk. The machine or yourself can be damaged or injured if procedures are not carried out in the correct way.



WARNING

The life of the operator can be at risk.

WARNING



WARNING

*Before you operate or carry out any maintenance on this machine **YOU MUST READ** and **STUDY** this manual.*

KNOW how to safely use the unit's controls and what you must do for safe maintenance. (NB Be sure that you know how to switch the machine off before you switch on, in case you get into difficulty.)

ALWAYS wear or use the proper safety items required for your personal protection. If you have **ANY QUESTIONS** about the safe use or maintenance of this unit, ASK YOUR SUPERVISOR OR CONTACT: **Altrad Belle (UK): +44 (0) 1298 84606**

ENSURE you make a note of the serial numbers of your machine and always quote them in any communication with Altrad Belle or one of our dealers.

A - MACHINE SERIAL NUMBER

B - POWER UNIT SERIAL NUMBER

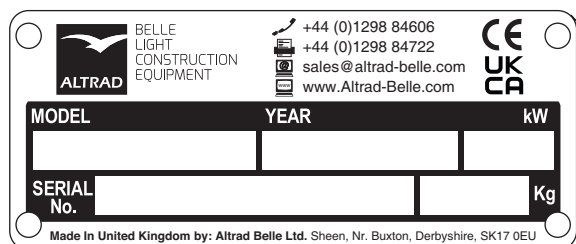

A

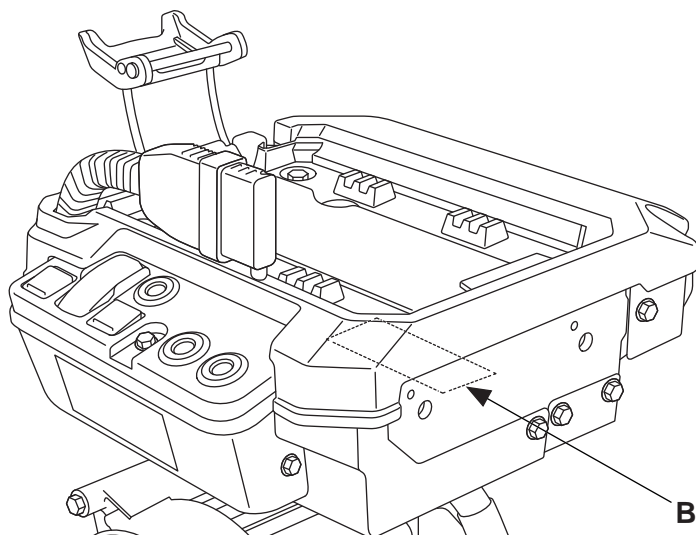
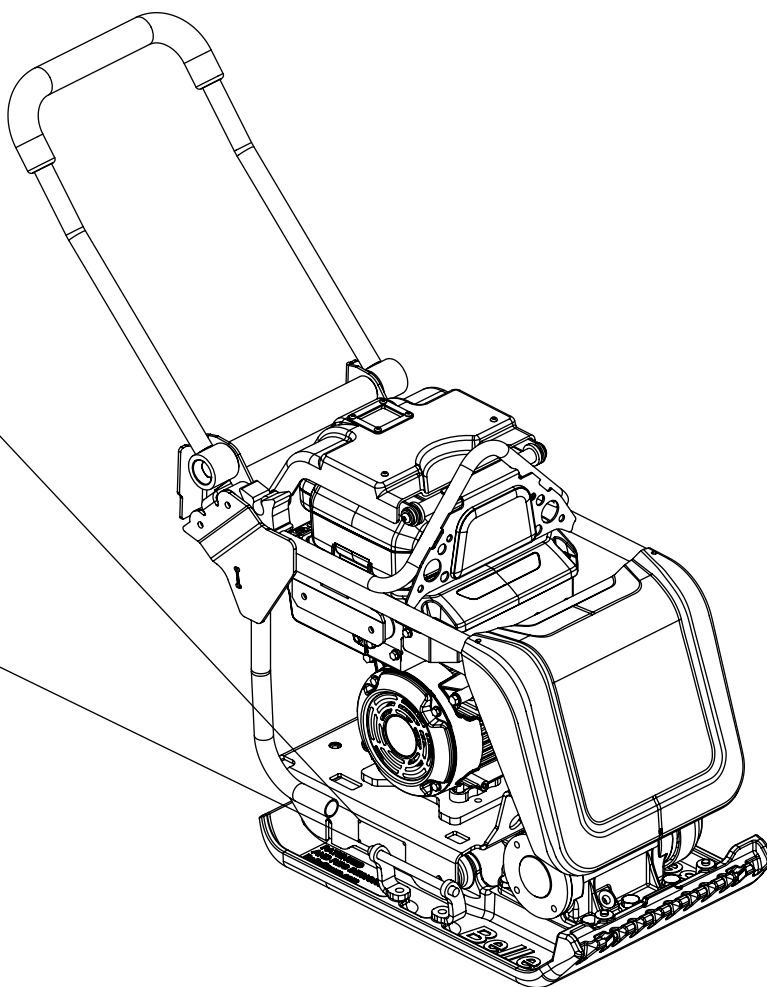

GENERAL

Heavyweight, professional combination compaction plate designed with an emission free, Li-ion battery powered motor for all your compaction requirements, indoor usage and poorly ventilated areas.

Produces low HAV values and matches the high performance compaction of its petrol powered equivalent, but without the environmental impact...***Building a Sustainable Future!***

STANDARD OPERATION

The machine is intended to be used for the following, in safe environmental conditions as described in this manual.

- Cohesive materials (less than 20% granular) e.g clay, silt & heavy soils.
- Granular materials (more than 20% granular) e.g hard core, sand & light soils.
- Bituminous materials e.g asphalt (tarmac), cold lay (bitumin emulsion products).

Any other use is not deemed suitable for this machine. Altrad Belle will not liable for any damage or injury resulting from any use other than outlined above. The operator will be liable.

Any unauthorised modifications or attachments are prohibited. They may affect the performance and safety of the machine, potentially resulting in damage to the machine or injury to the operator.

Use of non-genuine replacement parts may also affect the performance and safety of the machine. potentially resulting in damage to the machine or injury to the operator.

DANGER ZONE

The danger zone is the area around the machine in which persons are endangered during standard operation as outlined above.

During operation of the machine, cordon off the work area and keep members of the public and unauthorized personnel at a safe distance away from the danger zone.

MAIN COMPONENT LOCATIONS

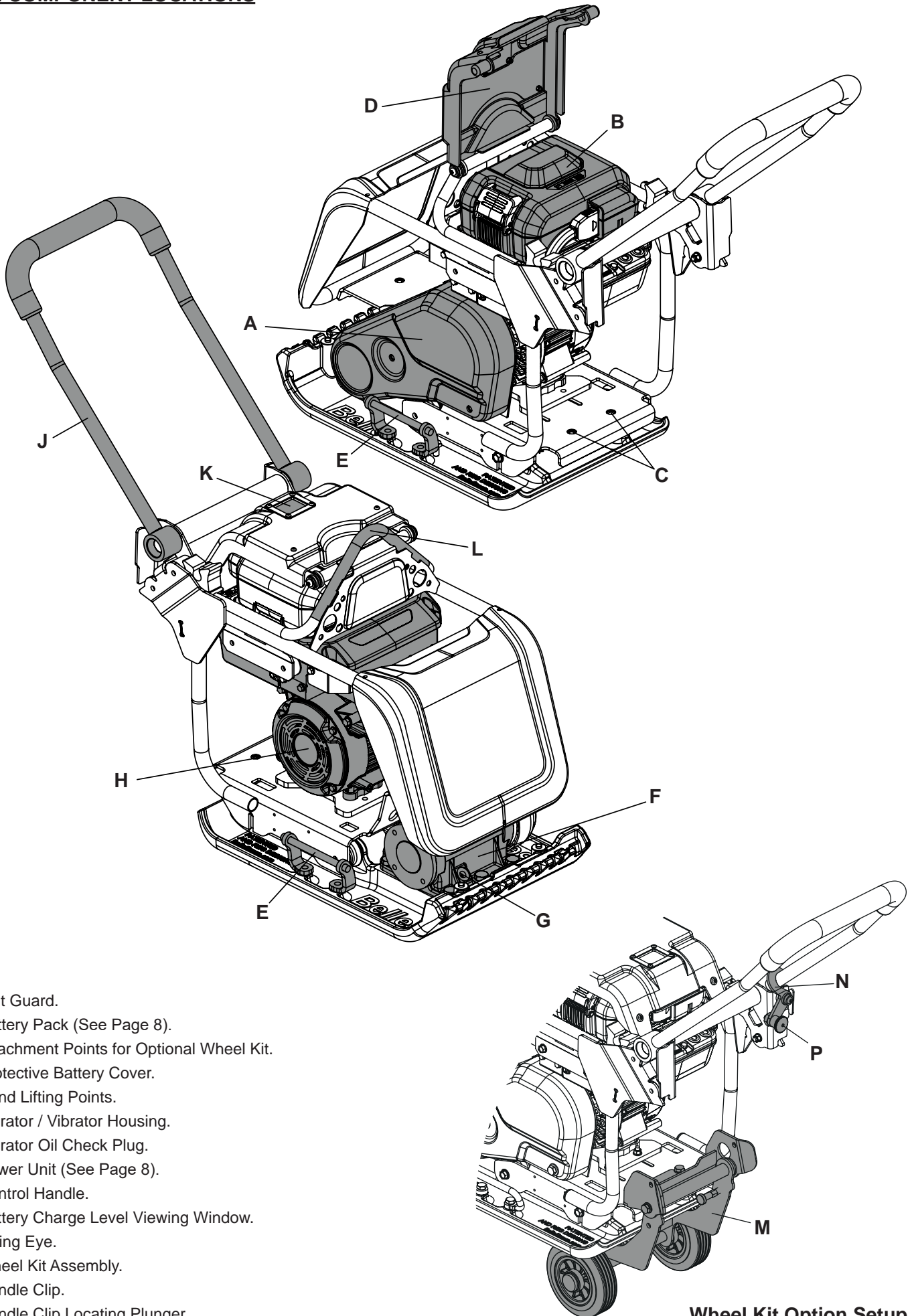

Wheel Kit Option Setup

POWER UNIT COMPONENTS

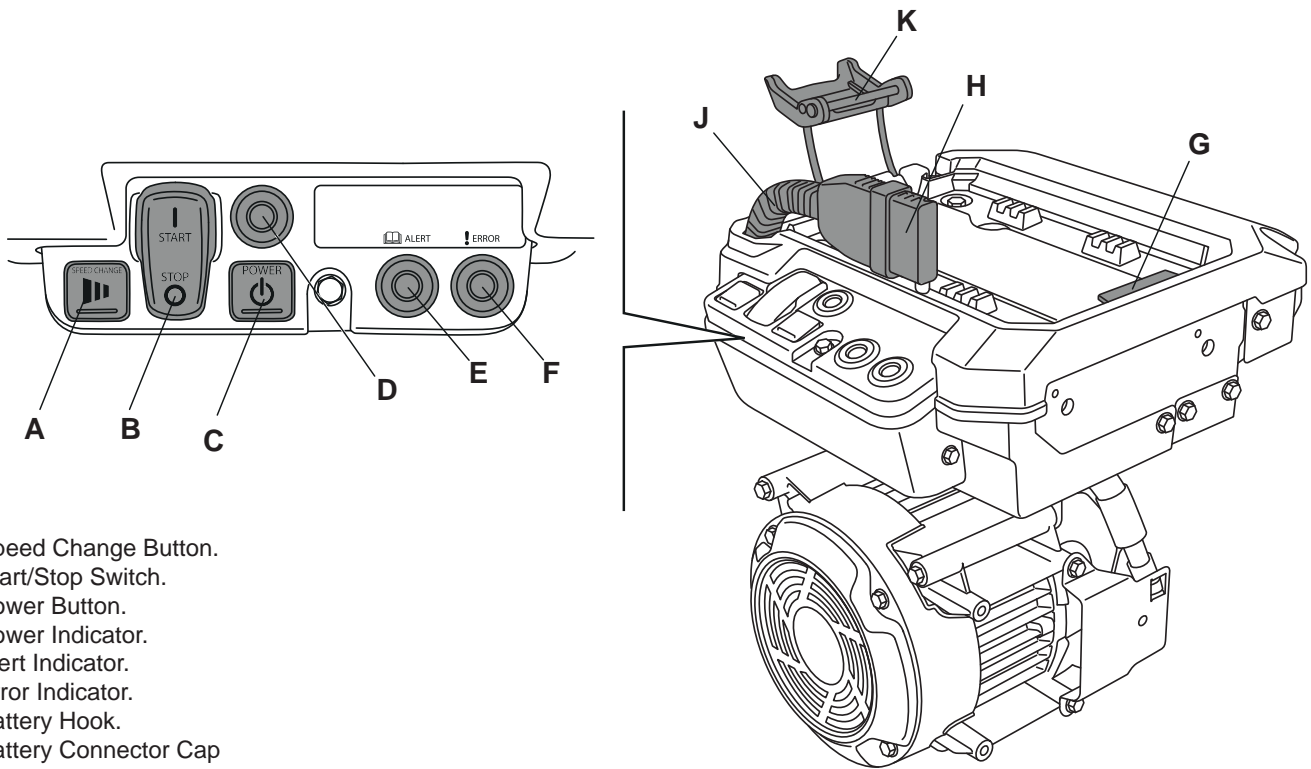

- A. Speed Change Button.
- B. Start/Stop Switch.
- C. Power Button.
- D. Power Indicator.
- E. Alert Indicator.
- F. Error Indicator.
- G. Battery Hook.
- H. Battery Connector Cap
- J. Power Cable.
- K. Battery Retaining Lever.

BATTERY PACK COMPONENTS

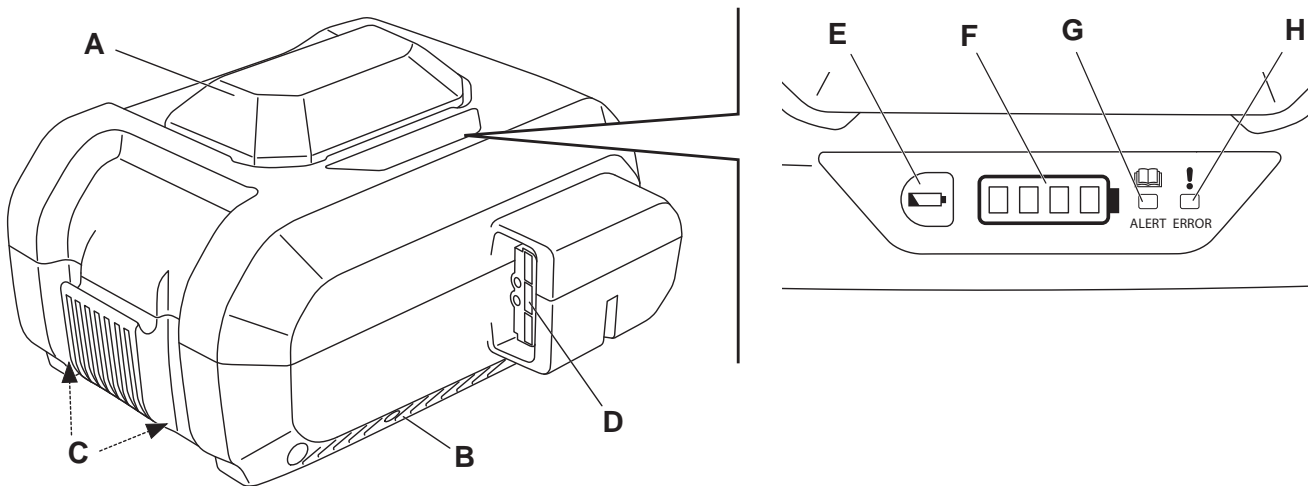

- A. Handle.
- B. Intake Port (both sides).
- C. Exhaust Port (bottom).
- D. Battery Connector.
- E. Charge Level Check Button.
- F. Charge Level Indicator.
- G. ALERT Indicator.
- H. ERROR Indicator.

BATTERY CHARGER

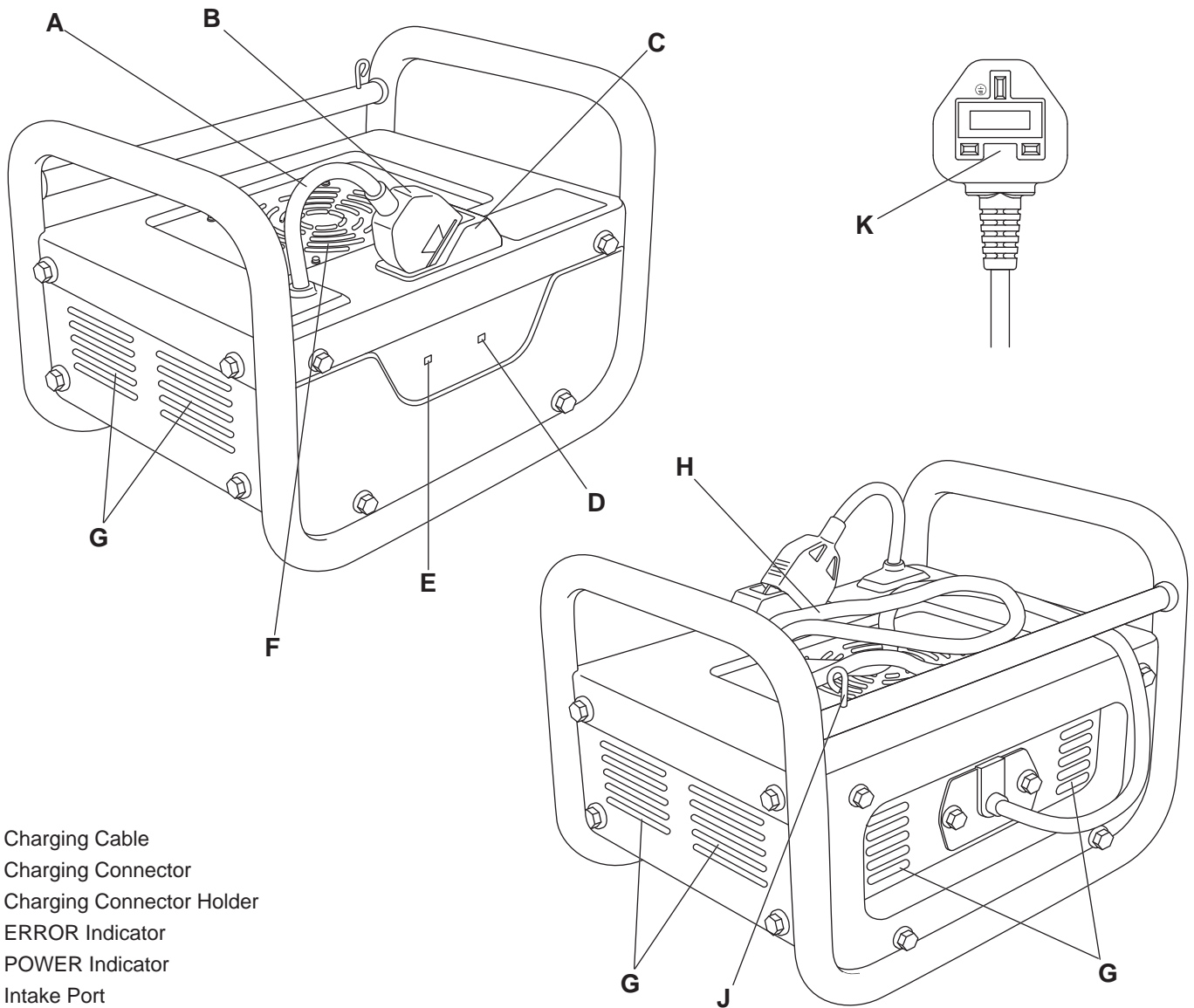

- A. Charging Cable
- B. Charging Connector
- C. Charging Connector Holder
- D. ERROR Indicator
- E. POWER Indicator
- F. Intake Port
- G. Exhaust Port
- H. AC Cable
- J. AC Plug Holder
- K. AC Plug

STATIC DIMENSIONS

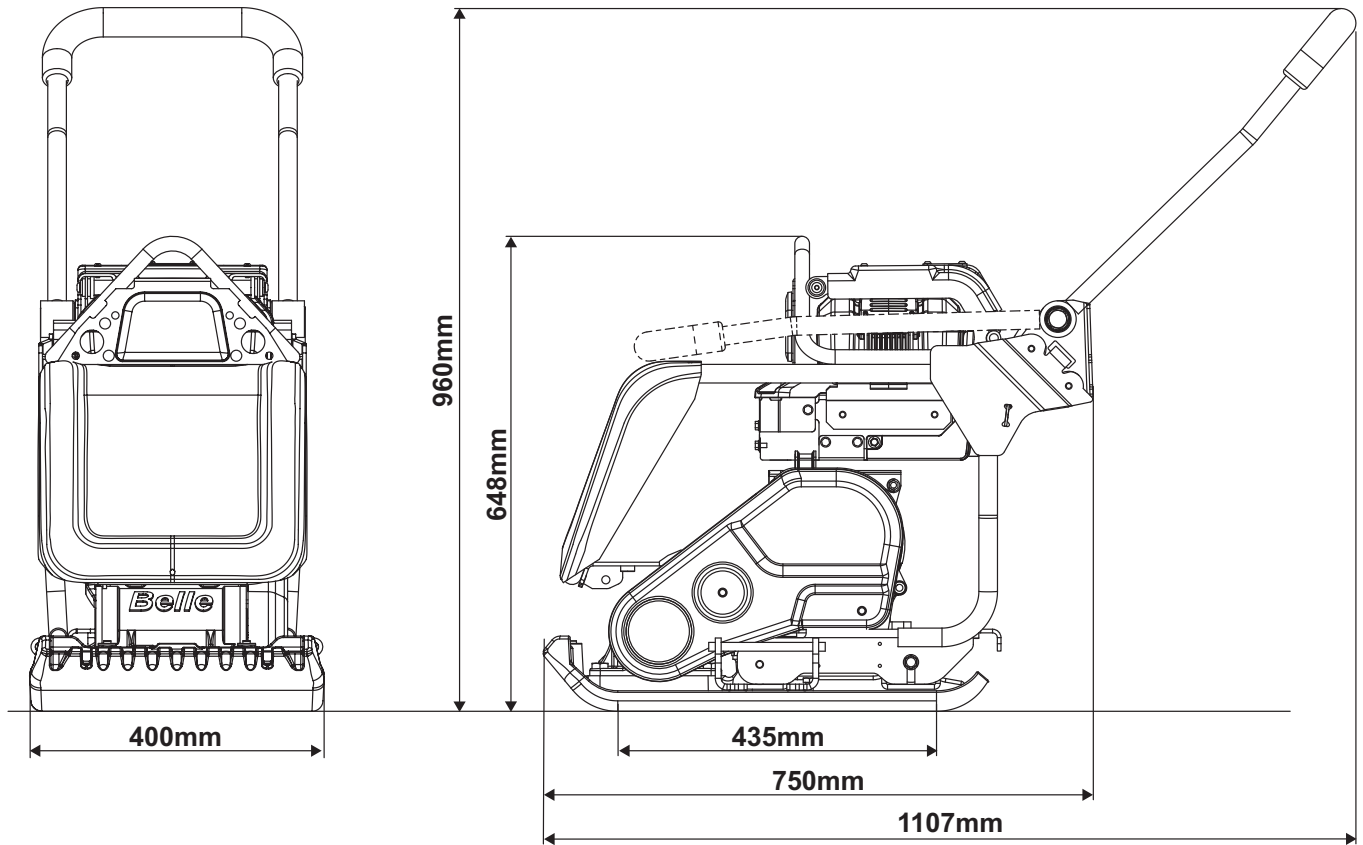

Model	PCX 13/40E+
** Motor (Hp / kW)	2.2 / 1.6
Vibrator Force (KN)	13
Frequency (Hz)	101
Static Pressure (kg/m ²)	560
Max Gradient (°)	20
Travel Speed (m/min)	20
* HAV Level (m/s ²)	<2.5
Weight (kg)	89
Motor RPM:	3600 / 3000 / 2800
Sound Power Level (dB(A))	101

* Minimum level to EN500 Part 4.

** The power rating of the petrol engines indicated in this document is the net power tested on a production petrol engine for the petrol engine model and measured in accordance with SAE J1349 at a specified rpm. Mass production petrol engines may vary from this value. Actual power output for the petrol engine installed in the final machine will vary depending on numerous factors, including the operating speed of the petrol engine in application, environmental conditions, maintenance and other variables. Honda reserves the right to modify its specifications at any time and without notice.



Technical Data

Model	Honda eGX Battery
Battery Type	Li-Ion
Weight (kg)	6.4
Dimensions LxWxH (mm)	268 x 233 x 150
Voltage: (V)	72
Energy Rating (Wh)	720
Energy Capacity (Ah)	10
Charge Time (Hr)	1.10

Model	Honda eGX Battery Charger
Dimensions LxWxH (mm)	266 x 352 x 247
Weight (kg)	11
Input Voltage AC (v)	100 to 240
Input Frequency (Hz)	50 / 60
Output voltage DC (v)	82.8
Output current (A)	8.5
Batteries that can be charged	DP72104Z
Charging temperature range (°C / °F)	5 to 30 / 41 to 86

GENERAL SAFETY

For your own personal protection and for the safety of those around you, please read and ensure you fully understand the following safety information. It is the responsibility of the operator to ensure that he/she fully understands how to operate this equipment safely. If you are unsure about the safe and correct use of the machine, consult your supervisor or Altrad Belle.



WARNING

Improper maintenance can be hazardous. Read and Understand this section before you perform any maintenance, service or repairs.

This machine is designed to eliminate the possible risks arising from the use of it. However, risks **DO** reside, and these residual risks are not clearly recognizable, and may cause personal injury or property damage, and possible death. If such unpredictable and unrecognizable risks become apparent, the machine must be stopped immediately, and operator or his supervisor must take appropriate measure to eliminate such risks. It is sometimes necessary that the manufacturer must be informed of such event for future counter measuring.

ALWAYS keep the Operator's Manual and any other manuals that accompany this machine to hand. Immediately replace any manuals that may have been lost or are now illegible.

PRE-START CHECKS

The following Pre-start-up inspection must be performed before the start of each work session or after every four hours of use, whichever is first. Please refer to the service section for detailed guidance. If any fault is discovered, the machine must not be used until the fault is rectified.

1. Thoroughly inspect the machine for signs of damage. Check components are present and secure.
2. **ENSURE** there is no debris or excessive dirt present on the machine.
3. **ENSURE** the battery pack is securely attached to power unit and the power cable is connected.
4. **ENSURE** the battery pack is sufficiently charged.

Once all the above checks have been made, test run the machine checking that all switches function correctly and all indicators light when the power unit is turned on.

WORKSITES

- **ENSURE** the operator is familiar with the working surroundings. Worksites can be hazardous.
- **ALWAYS** keep the work area tidy and clear of any obstructions that may lead to accidents and/or injuries.
- Cordon off the work area and keep members of the public and unauthorized personnel at a safe distance.
- This machine is heavy and must not be lifted single-handedly, either **GET HELP** or use suitable lifting equipment. A Wheel Kit Transport option is also available for this machine (see our website Altrad-Belle.com)

OPERATING THE MACHINE

- **ENSURE** the operator has had adequate training prior to use, is familiar with all controls and knows how to safely switch the machine **OFF** before it is switched **ON** in case you get into difficulty.
- Suitable **PPE MUST** be worn when using this equipment i.e. Safety Goggles, Gloves, Ear Defenders, Dust Mask and Steel Toe capped footwear (with anti-slip soles for added protection). Wear clothing suitable for the work you are doing and **DO NOT** wear loose jewellery that could be caught in moving parts
- **ALWAYS** inform colleagues of what you will be doing and where you will be working.
- **DO NOT** operate the machine when you are ill, feeling tired, or when under the influence of drugs / alcohol.
- **NEVER** leave the power unit running and unattended.
- **NEVER** remove or tamper with any guards fitted, they are there for your protection. Always check guards for condition and security, if any are damaged or missing, **DO NOT USE THE MACHINE** until the guard has been replaced or repaired.
- When working on a gradient **ALWAYS** work up and down the slope, not across.
- **ALWAYS** proceed with caution when working around utilities (gas, water pipes electrical lines)
- **ENSURE** extra care is taken when working near to banks or trenches where there is a danger of the material collapsing.
- When working within trenches or pits **ALWAYS** pay attention to the side walls as the vibration from the machine could cause them to collapse.
- Some vibration from the compaction operation is transmitted through the handle to the operator's hands. The Altrad Belle Plate Compactor range has been specifically designed to reduce hand/arm vibration levels. Refer to the Technical Data section for vibration levels and usage times (recommended maximum daily exposure time). **DO NOT** exceed the maximum usage times.
- The compacting process will occasionally produce dust, which may be hazardous to your health. Always wear a mask that is suited to the type of dust being produced.



Safety Instructions

BATTERY CHARGER

- To reduce risk of injury, charge **ONLY DP72104Z** type rechargeable batteries. Other types of batteries may burst causing personal injury and damage.
- This Battery Charger is not intended for use by children or persons with physical, sensory or mental limitations or a lack of experience or knowledge. **DO NOT** allow children to play with this Battery Charger - **IT IS NOT A TOY!**
- Charge only Li-ion Honda Battery Packs that have a capacity of 10 Ah with 80 battery cells. The battery voltage must match the battery charging voltage of the Battery Charger. **DO NOT** charge non-rechargeable Battery Packs, otherwise there is danger of fire and explosion.
- Continued use of the Battery Charger under unusual conditions could result in fire or electric shock, which may kill or seriously hurt you.
- **DO NOT** modify the Battery Charger. Modifying, disassembling or repairing the Battery Charger could result in fire or electric shock, which can cause death or serious injury. Disassembly and repairs require specialized knowledge, contact your servicing dealer.
- Before using the Battery Charger / charging a Battery Pack, people who are using an electronic medical device must confirm how their device might be affected. The electromagnetic radiation produced during charging may affect the operation of electronic medical devices, which may kill or seriously hurt you.
- If the Battery Pack leaks fluid or smells strangely, stop using it and contact your servicing dealer. Battery Pack contains combustible organic solvents as an electrolyte solution. Mistakenly handling them may result in burns or serious injuries.

DO NOT use the Battery Charger in the following situations.

- Locations where the Battery Charger becomes unstable.
- Locations where there is flammable gas or combustible materials
- Locations that are very cold or very hot, such as in direct sunlight or near a heater
- Locations exposed to water or excessive humidity
- Locations where children or pets might play with it

ALWAYS follow the rules below.

- **DO NOT** charge Battery Packs if there is the risk of a lightning storm.
- **DO NOT** charge if the electric outlet is loose.
- **DO NOT** charge if the Battery Charger, AC cable, or the electric outlet is damaged or deformed, dusty, dirty, or rusty.
- **DO NOT** plug too many power cords into one electric outlet.
- **DO NOT** charge while the AC cable is wound up.
- **DO NOT** stand on or place heavy objects on the Battery Charger or AC cable.
- **DO NOT** pull or repeatedly bend the AC cable or charging cable with an excessive force.
- **DO NOT** touch the Battery Charger or AC cable if your hands are wet.
- **DO NOT** splash or submerge the Battery Charger or AC cable in water.
 - If the Battery Charger or AC cable is submerged in water while you are charging, do not touch the Battery Charger or AC cable. Contact your servicing dealer.
- **DO NOT** leave the AC plug plugged into the electric outlet after you finish charging.
- **DO NOT** pull on the cable when you pull out the AC plug.
- **DO NOT** subject the Battery Charger to excessive physical shock, such as by dropping or hitting it.
- **DO NOT** use the Battery Charger to charge anything except Honda Battery Packs. Use only authentic Battery Packs. Charging a non-authentic Battery Pack could damage it and the charger because of poor protection functions, etc.
- **DO NOT** touch the Battery Pack terminals with metal. Mishandling them could result in electric shock or fire, which may kill or seriously hurt you. Follow the procedures and instructions provided in the manufacturers manual.

BATTERY PACK

- **ALWAYS** use a genuine battery pack that is intended for this machine.
DO NOT touch the Battery Pack's connectors with metal objects or insert metal objects through openings into the Battery Pack.
- **ALWAYS** keep the battery pack clean and dry.
- **NEVER** allow the battery pack to come into contact with water.
- If the Battery Pack leaks fluid or smells strangely, **IMMEDIATELY** move it away from any heat sources or flame. There is a risk of fire or rupturing if the leaked liquid or gas ignites.
- The Battery Pack contains combustible organic solvents as an electrolyte solution. If the liquid gets into your eyes, rinse them with plenty of water. After that, **IMMEDIATELY** seek medical care.
- **DO NOT** allow children to use the Battery Pack. Store the Battery Pack out of the reach of children.
- **DO NOT** store the Battery Pack in a damp location. Doing so can cause a malfunction.
- When the Battery Pack is not in use, keep it away from other metal objects, like paper clips, coins, keys, nails, screws or other small metal objects, that can make a connection from one terminal to another. Shorting the battery terminals together may cause burns or a fire.
- In case of fire, **STOP** using the machine immediately and extinguish with dry chemical, sandy soil, carbon dioxide or appropriate foam.
- The Battery Pack will deteriorate if it is repeatedly charged and discharged, as well as if it is stored and not used.
- As the Battery Pack deteriorates, its full-charge capacity decreases and the length of time it can be used shortens. Once the full-charge capacity is reduced by deterioration, it cannot be recovered and cannot reach the charging capacity of a new Battery Pack.
- **ALWAYS** remove the battery pack from the power unit when carrying or checking it.
- **ONLY** charge the battery pack in a recommended charging unit.
- **DO NOT** expose the battery pack to extreme temperatures (below 5°C (41°F) or above 40°C (104°F))
- **NEVER** attempt to service a damaged battery pack.
- **WORK ON THE BATTERY PACK OR POWER UNIT MUST ONLY BE CARRIED OUT BY QUALIFIED PERSONNEL.**

WEATHER CONDITIONS

- We recommended that this machine not be used in heavy rain.
- Rain can alter the condition of the worksite surface area. **ALWAYS** be aware of the condition of the surface after it has rained.
- Operating the machine in poor visibility can result in serious injury or even death. **ALWAYS** use your lights to improve the visibility of the area.
- **NEVER** operate the machine in temperatures below 5°C (41°F) or above 40°C (104°F)

DURING MAINTENANCE

- **ALWAYS** remove the battery before carrying out any maintenance on the machine.
- Carry out maintenance and repair work only if the machine is positioned on stable and level ground and has been secured against inadvertent movement.
- **NEVER** service the machine while the power unit is running, always switch **OFF**.
- Clean the machine, especially connections and threaded unions, before carrying out maintenance/repair.
- When dismantling assemblies containing components under pressure from springs, always wear suitable PPE. This will protect against eye injuries from accidental flying components.
- When handling oil, grease and other chemical substances, observe the product related safety regulations.

AFTER MAINTENANCE

- **ALWAYS** tighten any screwed connections that have been loosened during maintenance and repair.
- Any safety devices removed for set-up, maintenance or repair purposes must be refitted and checked immediately upon completion of the maintenance and repair work.
- **ENSURE** that all consumables and replaced parts are disposed of safely and with minimum environmental impact.

MODIFICATIONS & REPLACEMENT PARTS

- **NEVER** make any modifications or additions to the machine without the prior approval of Altrad Belle. Any unapproved modifications may affect the performance and safety of the machine. This may also void the Warranty.
- **ALWAYS** use genuine Altrad Belle replacement parts. Use of non-genuine replacement parts may affect the performance and safety of the machine. This may also void the Warranty.

Genuine Altrad Belle replacement parts can be purchased online at www.Altrad-Belle247.com

SAFETY DECALS

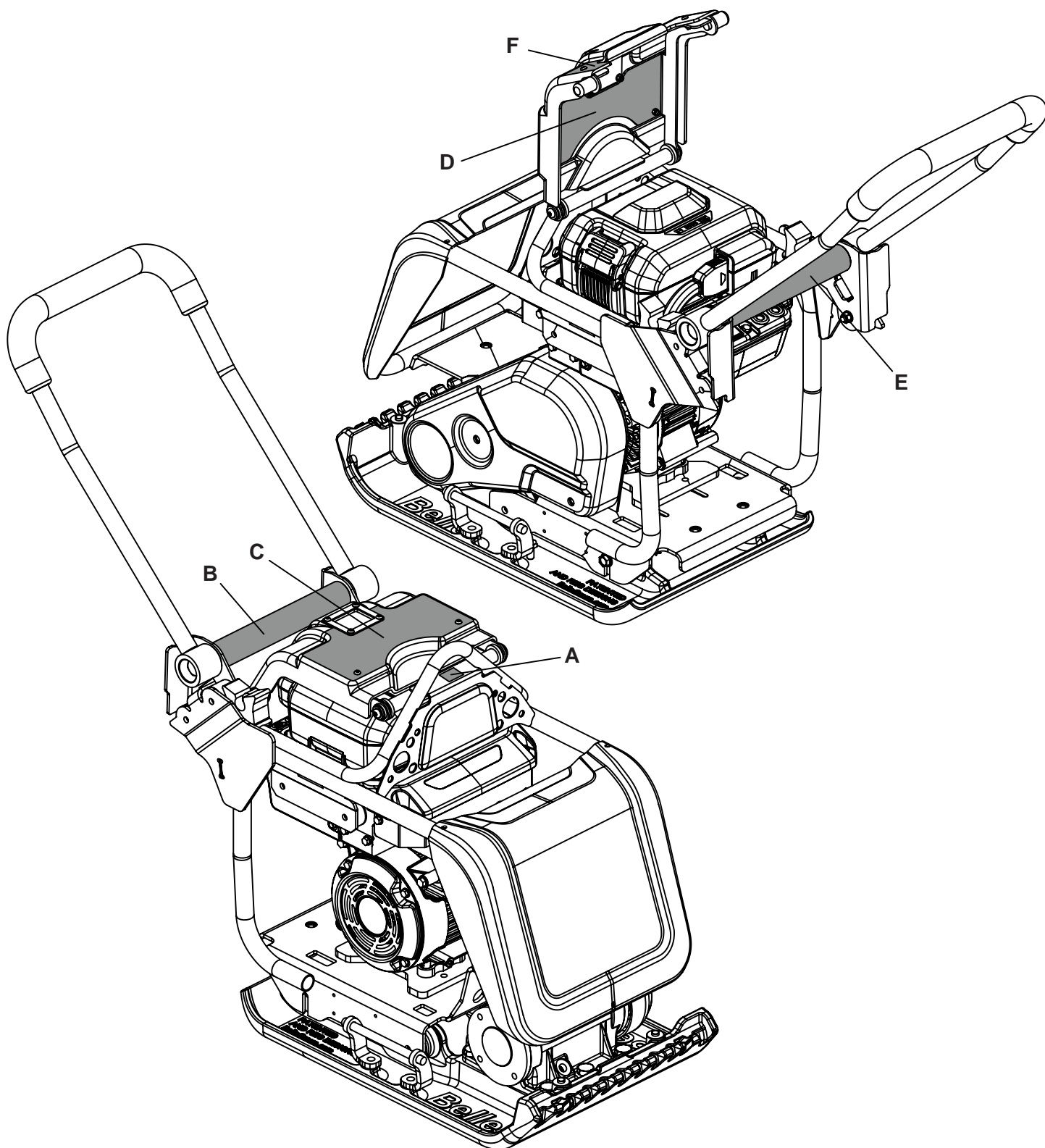

- A. Lifting Point Decal
- B. Low HAV Decal.
- C. General Safety / Info Decal.
- D. Operating Instructions Decal.
- E. Handle Latch Decal
- F. Speed Setting Decal

SAFETY DECALS

A - Lifting Point Decal

Lifting point for use with a Sling or Mechanical Hoist.

B. Low HAV Decal.

Highlights that the machine has a HAV level low enough that it can be used for more than 8hrs.

C. General Safety / Info Decal.



**Read the
Operators
Manual**



**Wear Ear
Protection**



**Wear Eye
Protection**



**Wear Protective
Footwear**



***Indicates the
Noise Level
of the
Machine**

** Also see Technical Data section for Noise Level for this machine.*

D. Operating Instructions Decal.

Includes information on how to Start and Stop the Power Unit.



**DO NOT
Jetwash the
Machine**

E. Handle Latch Decal.

The Handle Latch is not required when the Wheel Kit is not in use.

1. Disengage the Wheel Kit.
2. Pull the plunger and rotate the latch anti-clock wise to its stop position. Release the plunger to lock the latch in the unlock position.

The Handle Latch is **ALWAYS** required when the Wheel Kit is engaged.

1. Pull the plunger and rotate the latch clock wise until it locates over the handle tube. Release the plunger to lock the latch in the lock position.
2. Engage the Wheel Kit.

F. Speed Setting Decal.

Highlights that the compactor has 3 speed settings which can be altered by pressing the 'Speed Chage' button on the power unit.



CAUTION

*The compactor **ALWAYS** starts on the fastest speed when the power unit turned ON.*



Operating Instructions

REASONS FOR COMPACTION

Soil, which has been disturbed or new infill, subbase and blacktop, will have small voids or air pockets which, if not compacted, will lead to one or more problems occurring.

1. As traffic crosses the surface of an uncompacted area, the material is compressed. This leads to subsidence of the top surface as the material fills the voids.
2. A similar situation occurs with static loads on uncompacted ground. The load (e.g. a building) will sink.
3. Materials with voids are more susceptible to water seepage, leading to erosion. Water ingress may also cause the soil to expand during freezing temperatures and contract during dry spells. Expansion and contraction is a major cause of damage to building foundations and normally leads to the structure requiring underpinning.
Compaction increases the density of the material and therefore increases its load bearing capacity. Reduces air voids and therefore reduces the risk of subsidence, expansion and contraction, due to ingress of water.

APPLICATIONS

Applications/materials fall into three categories:

1. Cohesive materials (less than 20% granular) e.g clay, silt & heavy soils.
2. Granular materials (more than 20% granular) e.g hard core, sand & light soils.
3. Bituminous materials e.g asphalt (tarmac), cold lay (bitumin emulsion products).

The chart shows the HAUC specifications for layer depth and number of passes for Dual Force' plates. If standard machines are used, optimum compaction can not be guaranteed, however, if layer depths are reduced and number of passes increased, results can be improved.

Moisture content of cohesive & granular materials is critical to effective compaction. If granular material is too dry it will flow around the plate instead of compacting. If the moisture content is too high the material may dry out after compaction and shrinkage will occur.

1400 - 1800 kg/m ²	COMPACTION PASSES REQUIRED PER LAYER OF COMPACTED THICKNESS UP TO.				
	40mm	60mm	80mm	100mm	150mm
Cohesive Materials**	2**	4**	5**	6**	Reduce Layer Thickness
Granular Materials	2*	3*	4*	5	9
Bituminous	6	10	12		Reduce Layer Thickness

* Usually placed in 100mm minimum layer so not specified by HAUC.

** The nature of cohesive materials makes plate compaction difficult. Optimum compaction is not guaranteed and not recommended by HAUC.

CHARGING THE BATTERY PACK

Refer to the Battery Charger manual for instructions on how to charge the Battery Pack.

ATTACHING THE BATTERY PACK



CAUTION *ALWAYS make sure to use a genuine, recommended Battery Pack.*

Refer to the Machine Description section to identify the components.

1. Make sure there is no debris or dirt on the battery tray.
2. Tilt the Battery Pack and insert its claw into the battery hook.
3. Push down the Battery Pack and hook the battery fastener to it.
4. Push the battery fastener lever up and lock the Battery Pack. Be careful not to catch your fingers.
5. Remove the battery connector cap from the power cable. Connect the power cable to the battery connector of the Battery Pack.

STOPPING THE POWER UNIT

Refer to the Machine Description section to identify the components.

1. Press the **START/STOP** switch to the **STOP** position. The DC Power Unit will stop and the **POWER** indicator turns off.

STARTING THE POWER UNIT

Refer to the Machine Description section to identify the components.

1. Press **STOP** on the **START/STOP** switch.
2. Press the **POWER** button.
All the indicators should illuminate for a few seconds, and then only the **POWER** indicator remains illuminated.
3. Press the **START/STOP** switch to the **START** position to start the Power Unit.
4. Push the **SPEED CHANGE** button to set the Power Unit speed as required.
 - If the **POWER** button is pressed when the **START/STOP** switch is in the **START** position, the **POWER** indicator remains off and the **ALERT** indicator flashes. In this case, the Power Unit cannot start. Press the **START/STOP** switch to the **STOP** position and then press the **POWER** button.
 - It may take some time for the indicators to light after the **POWER** button is pressed. If the indicators do not light, press the **POWER** button again.
 - If the Power Unit is not operated for about one minute after the **POWER** button is pressed, the **POWER** indicator turns off. Press the **POWER** button again to start the Power Unit.

REMOVING THE BATTERY PACK

Refer to the Machine Description section to identify the components.



CAUTION *ENSURE the machine is switched OFF before removing the battery.*

1. Remove the power cable from the Battery Pack.
2. Pull the battery fastener down to unlock, tilt the Battery Pack up and pull the Battery Pack claw out from the battery hook, and remove the Battery Pack.
3. Attach the battery connector cap to the power cable.

CHECKING THE CHARGE LEVEL OF THE BATTERY PACK

While the Power Unit is operating, the charge level indicator lights or flashes so you can confirm the charge level of the Battery Pack.

While the Power Unit is stopped, press the charge level check button to confirm the charge level of the Battery Pack.

Indicator Display	Charge Level	
	High ↓ Low	Fully charged.
		Sufficiently charged.
		Remaining battery power is low. Charge the Battery Pack.

■ :On, ✱ : Flashing, □ :Off

TRANSPORTATION



CAUTION

We **RECOMMEND** removing the battery pack from the power unit before transporting the machine.

Transporting the machine is a 2 person operation. Use the provided Hand Lifting Points (See Machine Description section) **DO NOT** use a Mechanical Hoist on the Hand Lifting Points.

Where it is necessary to use lifting equipment to transport the machine, make sure the lifting equipment has a WLL (Working Load Limit) suitable for the machines weight (see Technical Data section). Attach suitable chains or slings **ONLY** to the lifting point on the top of the machine.

If using the optional Wheel Kit attachment the handle latch must **ALWAYS** be engaged using the following procedure.

1. Pull the plunger and rotate the latch clock wise until it locates over the handle tube. Release the plunger to lock the latch in the lock position.

The Wheel Kit can now be fitted as per the instructions provided with the Wheel Kit. Then tilt the machine forward to raise the transport wheels off the ground and underneath the baseplate. Then slowly lower the machine on top of the wheels.

To disengage the handle latch when the Wheel Kit is not in use, use the following procedure:-

1. Pull the plunger and rotate the latch anti-clock wise to its stop position. Release the plunger to lock the latch in the unlock position.



CAUTION

ALWAYS pull the machine backwards when using the optional Wheel Kit attachment.

OPERATING THE MACHINE

Having carried out the Pre-Start Checks listed in the Safety Instructions section of this manual, you may start the power unit.

The vibrator will not only cause the baseplate to vibrate but will also cause the machine to travel forward. During normal operation you should not have to push the machine forwards but allow it to travel at its own pace. The speed of travel will be determined by the condition of the surface being compacted.

If the surface to be compacted is on a slope, great care must be taken when controlling the machine's direction of travel. If necessary, use a suitable rope attached to the machine at a low point on the chassis, to allow a helper to take part of the machine's weight. Work up and down a slope not across.

Work the compactor over the surface in an organised pattern until the required compaction has been achieved. Where there are a number of different layers to be compacted on top of each other, compact each layer individually.

If the machine is not to be used for an long period of time it must be stored correctly to prevent deterioration or damage occurring during this period.

Store the machine in a clean dry building with plenty of ventilation if possible. If you can only store outdoors, cover with a waterproof sheet / tarpaulin.

PREPARING THE MACHINE FOR STORAGE

1. Clean the machine and remove all unwanted material / debris (See the Cleaning section on page 23).
2. Dry the machine to remove any moisture.
3. Apply grease to any moving parts / grease points.
4. Examine the machine for any worn / damaged parts. Replace if necessary.

STORING THE MACHINE

1. Place the machine safely on stable, level ground.
ENSURE there is sufficient room around the machine to be able to carry out any service or maintenance procedures during the storage period.
2. Remove the battery pack and store correctly (See page 19)

DURING STORAGE

To prevent the build up of rust and to minimise the risk of seizures, periodically operate all machine functions during storage.

1. Install a fully charged battery.
2. Start the power unit.
3. Operate all machine functions. **ENSURE** they all operate correctly.
4. Re-do storage procedure from above.

REMOVING THE MACHINE FROM STORAGE

1. Install a fully charged battery.
2. Carry out the Pre-Start Check procedure (See page 12)



Service and Maintenance

GENERAL

This machine is designed to give many years of trouble free operation. It is, however, important that the simple regular maintenance listed in this section is carried out. All maintenance procedures must be carried out by a competent, suitably qualified person.

A poorly maintained machine could be a danger to the operator and the other personnel on the worksite. **ENSURE** that the regular maintenance procedures listed in this manual are performed correctly and on time to keep the machine safe and efficient.

ALWAYS use genuine Altrad Belle replacement parts, the use of spurious parts may void your warranty.

Before any maintenance is carried out on the machine, switch off the machine and **ALWAYS** set the machine on stable, level ground.

ENSURE any faults identified during maintenance procedures are addressed and corrected immediately.

Routine Maintenance (1)			Each Use	Every 5 Years or 250 Hours
Exterior		Check	✓	
Switch		Check	✓	
LED		Check	✓	
Power Cable		Check	✓	
Motor Wire Harness		Check	✓	
Wires Harness		Check		✓ (2)(4)
Battery Fastener		Check	✓	
		Replace		✓(2)
Rubber Support		Check	✓	
		Replace		✓(2)
Battery Hook		Check	✓	
		Replace		✓(2)
Set Speed	Rated Speed	Check	When Required (3)	
	Medium Speed	Check		
	Low Speed	Check		

(1) Perform at every indicated time or operating hours interval, whichever comes first.

(2) These items should be serviced by your servicing dealer, unless you have the proper tools and are mechanically proficient. Consult Altrad Belle.

(3) Speed is set to 3600 min⁻¹(rpm) (**rated speed**), 3300 min⁻¹(rpm) (**medium speed**) or 3000 min⁻¹(rpm) (**low speed**). If the Power Unit makes an unusual sound, have it inspected by your servicing dealer.

(4) Replace if necessary.

DRIVE BELT

Remove the belt guard then check the belt tension by placing light finger pressure on the top of the belt, as near central between the power unit drive and vibrator pulley. The belt should deflect by between 5mm and 10mm.

If the belt tension requires adjustment, remove the belt. Loosen the four power unit mounting bolts (Highlighted Grey in the adjacent diagram (1 bolt is hidden by the power unit)) enough to allow the power unit to be moved. Once set, refit the belt and check the belt tension a second time. If the belt tension is correct, retighten the power unit mounting bolts. If the Belt remains loose, replace the belt.

Finally, replace the belt guard ensuring it is correctly and securely fitted.

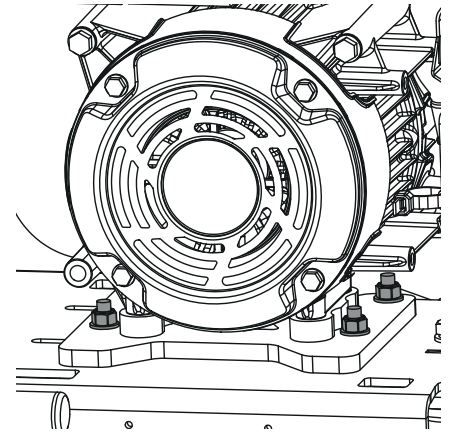

VIBRATOR UNIT

Place the machine safely on stable, level ground. Remove the plug complete with seal, check that the oil level reaches the bottom thread on the oil plug hole. Top up as necessary with the correct oil (see chart below).

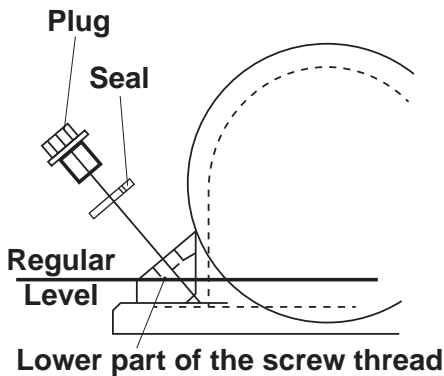

Component	Oil Type	Quantity
Vibrator	Turbine Oil 32	0.3 Litres

CLEANING

Keeping the machine clean is an integral part of the service and maintenance program. The build-up of mud, dirt and debris could potentially affect the operating safety of the machine, exposing both the operator and other personnel to potentially hazardous situations.



WARNING

NEVER use a hose or pressure washer to spray water on the machine while cleaning it. Water entering the components may cause a malfunction and/or injury.

ALWAYS clean the machine using compressed air and wipe the battery pack clean with a dry, clean cloth. Before cleaning the Battery Pack, remove it from the specified device or the Battery Charger.

After the cleaning process check that all cables, hoses and fasteners are in place and secure. Replace any if necessary. Also **ENSURE** that all safety / warning decals are present in their correct locations. Replace any if necessary.

POWER UNIT & OPERATION

Problem	Cause	Remedy
Power Unit does not operate.	Battery Pack is not attached correctly	Refer to "Attaching The Battery Pack" section and check that the power cable and Battery Pack are attached correctly.
	Battery power is low.	Charge the Battery Pack.
	Battery Pack has malfunctioned.	Replace the Battery Pack.
ALERT indicator is flashing.	Protection function is engaged.	Contact Agent or Altrad Belle.
	When starting the Power Unit, the POWER button was pressed while the START/STOP switch was in the START position.	Press the START/STOP switch to the STOP position and then press the POWER button.
	The Power Unit becomes too hot. (POWER indicator lights)	Stop using the machine and let the Power Unit cool down.
ERROR indicator is lit.	Protection function is engaged.	Contact Agent or Altrad Belle.
Machine will not vibrate.	Power Unit speed too slow.	Contact agent or Altrad Belle.
	Drive belt tension loose.	Adjust belt tension.
	Drive failure.	Contact Agent or Altrad Belle.
	Vibrator failure.	Contact Agent or Altrad Belle.
Asphalt adhering to plate.	Lack of lubrication.	Use a water spray system.
Paving blocks damaged.	Plate in direct contact with material.	Use a paving pad.
Bituminous surface flaking (laminating).	Over compaction.	Remove and relay.
Low travel speed (plate sinking).	Layer thickness too deep.	Remove some of the material.
	Moisture content too high or too low.	Remove material and adjust.

BATTERY PACK

Indicator			Cause	Remedy
ALERT	ERROR	Charge Level		
Flash	-	-	Problem was detected.	Remove all equipment connected to the Battery Pack, wait for about 5 minutes and press the Charge Level Check Button. • When the ALERT indicator does not flash, the Battery Pack can be used normally.
		4 indicators flash	Problem was detected. (Overvoltage protection)	After following the instructions for the Battery Pack problem, connect the specified device and check if it works properly. • When the device works, the Battery Pack can be used normally.
		1 indicators flash	Problem was detected. (Low voltage protection)	After following the instructions for the Battery Pack problem, connect the Battery Charger and check if the charging starts properly. • When the charging starts, the Battery Pack can be used normally.
-	Illuminate	-	Problem with the specified device or Battery Charger, or malfunction in the Battery Pack was detected.	Remove all equipment connected to the Battery Pack, wait until all indicators turn off and press the Charge Level Check Button. • When the ERROR indicator does not illuminate, the Battery Pack can be used normally. Check that there is no foreign material around the Battery Pack. Connect the specified device or Battery Charger. • When the ERROR indicator illuminates, there is a problem with the specified device or Battery Charger.
	Flash		Malfunction was detected.	Battery Pack is dead. Replace the Battery Pack.

BATTERY CHARGER

Problem	Cause	Remedy
Charging does not start	The AC plug is not connected to an electric outlet.	Connect the AC plug to an electric outlet correctly.
	The charging connector is not connected to the battery connector.	Connect the charging connector to the battery connector correctly.
Charging stops midway	The Battery Pack is not being cooled correctly, so charging is stopped by the high-temperature protection function.	Position the Battery Pack so there are no gaps between the intake port of the Battery Charger and the exhaust port of the Battery Pack.
ERROR indicator is lit	Protection function is engaged.	Contact Altrad Belle.



Environment



Safe Disposal.

Instructions for the protection of the environment.

The machine contains valuable materials.

Take the discarded apparatus and accessories to the relevant recycling facilities.

Component	Material	Component	Material
Handle	Steel	Battery Pack	*See Below
Plastic Covers / Guards	HDPE	Battery Charger	*See Below
Main Frame	Steel	Flexible Mounts	Steel and Rubber
Baseplate	Steel	Various Parts	Steel and Aluminium
Hand Grips	Rubber	Water Bottle (If fitted)	Plastic
Power Unit	*See Below		

***DO NOT** dispose of electric equipment together with household waste material.

If electrical appliances are disposed of in landfills or dumps, substances can leak and react and enter into the foodchain, damaging your health and well-being. For further information on the disposal of this product, please contact your dealer or your nearest domestic waste collection service.



Replacement Parts

When maintaining this product only the manufacturers original, genuine replacement parts may be used.

The user will lose any possible claims if replacement parts used are other than the makers original replacement parts.

Replacement parts for this product can be ordered online 24 hours a day, 7 days a week at www.Altrad-Belle247.com

For more information regarding the availability of replacement parts for this product, please contact Altrad Belle using the following contact details:-

Tel:- +44 (0)1298 84606

Fax:- +44 (0)1298 84073

Email:- sales@altrad-belle.com

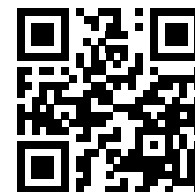

Alternatively, please scan the adjacent QR Code (Quick Response Code) using your smartphone to access the Altrad Belle online parts portal.

Your new Altrad Belle 'PCX 13/40E+' Single Direction Plate Compactor is warranted to the original purchaser for a period of one-year (12 months) from the original date of purchase. The Altrad Belle warranty is against defects in design, materials and workmanship.

The following are not covered under the Altrad Belle warranty:

1. Damage caused by abuse, misuse, dropping or other similar damage caused by or as a result of failure to follow assembly, operation or user maintenance instructions.
2. Alterations, additions or repairs carried out by persons other than Altrad Belle or their recognised agents.
3. Transportation or shipment costs to and from Altrad Belle or their recognised agents, for repair or assessment against a warranty claim, on any machine.
4. Materials and/or labour costs to renew, repair or replace components due to fair wear and tear.

The following components are not covered by warranty.

- Drivebelt/s

Please also consult the Honda DC Power Unit, Battery & Battery Charger manuals for further information on their warranty details.

Altrad Belle and/or their recognised agents, directors, employees or insurers will not be held liable for consequential or other damages, losses or expenses in connection with or by reason of or the inability to use the machine for any purpose.

Warranty Claims

All warranty claims should firstly be directed to Altrad Belle, either by telephone, by Fax, by Email, or in writing.

For warranty claims:

Tel: +44 (0)1298 84606

Fax: +44 (0)1298 84073

Email: warranty.dept@altrad-belle.com

Write to:

Altrad Belle Warranty Department,
Sheen, Nr. Buxton,
Derbyshire,
SK17 0EU
England.

Warranty Registration:

In the bid for Altrad Belle to become greener and more eco friendly, we have now introduced online Warranty registration. To access the registration page of our website, please use the following address:-

http://www.bellegroup.com/index.php?p=warranty_registration

Alternatively, please scan the adjacent QR Code (Quick Response Code) using your smartphone to access the registration page.





BELLE
LIGHT
CONSTRUCTION
EQUIPMENT

ALTRAD BELLE

Sheen, Nr. Buxton, Derbyshire, SK17 0EU, GB

Tel. +44 (0)1298 84606 - Fax +44 (0)1298 84722 - Email: sales@altrad-belle.com

www.Altrad-Belle.com

EU IMPORTER ADDRESS

ADRESSE DE L'IMPORTATEUR - DIRECCIÓN DEL IMPORTADOR - ENDEREÇO DO IMPORTADOR - ADRES IMPORTEUR

IMPORTØRENS ADRESSE - IMPORTEUR ADRESSE - INDIRIZZO DELL'IMPORTATORE - IMPORTÖRENS ADRESS - IMPORTØRADRESSE

MAAHANTUOJAN OSOITE - ADRES IMPORTERA - IMPORTIJA AADRESS - IMPORTĚTĀJA ADRESE - IMPORTUOTOJO ADRESAS

ADRESA DOVOZCE - ADRESA IMPORTATORULUI - IMPORTÓR CÍME - ADRESA UVOZNIKA - ÍTHALATÇI ADRESI - ADRESA DOVOZCU

ALTRAD (Group Holding)

125, Rue du Mas Carbonnier, 34000, Montpellier, France

Tel. +33 (0) 4 67 50 53 66 - Email: admin@altrad.com

www.altrad.com